

## Description

The 9ZML1233E/9ZML1253E are second generation enhanced performance DB1200ZL derivatives. The parts are pin-compatible upgrades to the 9ZML1232B, while offering much improved phase jitter performance. A fixed external feedback maintains low drift for critical QPI/UPI applications, while each input channel has software adjustable input-to-output delay to ease transport delay management for today's more complex server topologies. The 9ZML1233E and 9ZML1253E have an SMBus Write Lockout pin for increased device and system security.

## PCIe Clocking Architectures

- Common Clocked (CC)
- Independent Reference (IR) with and without spread spectrum

## Typical Applications

- Servers
- Storage
- Networking
- SSDs

## Output Features

- 12 Low-Power (LP) HCSL output pairs (1233E)
- 12 Low-Power (LP) HCSL output pairs with 85Ω Zout (1253E)

## Block Diagram

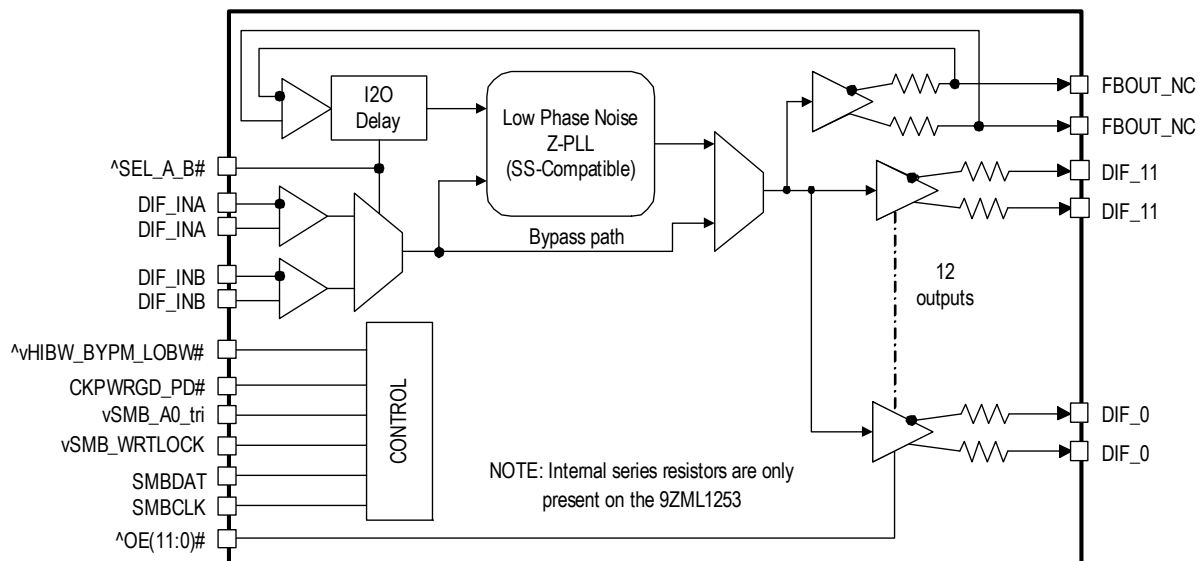

## Features

- SMBus write lock feature; increases system security
- 2 software-configurable input-to-output delay lines; manage transport delay for complex topologies
- LP-HCSL outputs; eliminate 24 resistors, save 41mm<sup>2</sup> of area (1233E)
- LP-HCSL outputs with 85Ω Zout; eliminate 48 resistors, save 82mm<sup>2</sup> of area (1253E)
- 12 OE# pins; hardware control of each output
- 3 selectable SMBus addresses; multiple devices can share same SMBus segment
- Selectable PLL bandwidths; minimizes jitter peaking in cascaded PLL topologies
- Hardware/SMBus control of PLL bandwidth and bypass; change mode without power cycle
- Spread spectrum compatible; tracks spreading input clock for EMI reduction
- 100MHz PLL Mode; UPI support
- 10 x 10 mm 72-VFQFPN package; small board footprint

## Key Specifications

- Cycle-to-cycle jitter < 50ps
- Output-to-output skew < 50ps
- Input-to-output delay: 0ps default
- Input-to-output delay variation < 50ps
- Phase jitter: PCIe Gen4 < 0.5ps rms
- Phase jitter: UPI > 9.6GB/s < 0.1ps rms
- Phase jitter: IF-UPI < 1.0ps rms

## Contents

Description .....	1
PCIe Clocking Architectures .....	1
Typical Applications .....	1
Output Features .....	1
Features .....	1
Key Specifications .....	1
Block Diagram .....	1
Pin Assignments .....	3
Pin Descriptions .....	3
Absolute Maximum Ratings .....	6
Electrical Characteristics .....	6
Clock Periods .....	15
General SMBus Serial Interface Information .....	16
How to Write .....	16
9ZML1233E/9ZML1253E SMBus Addressing .....	16
How to Read .....	16
Package Outline Drawings .....	20
Ordering Information .....	20
Revision History .....	21

## Pin Assignments

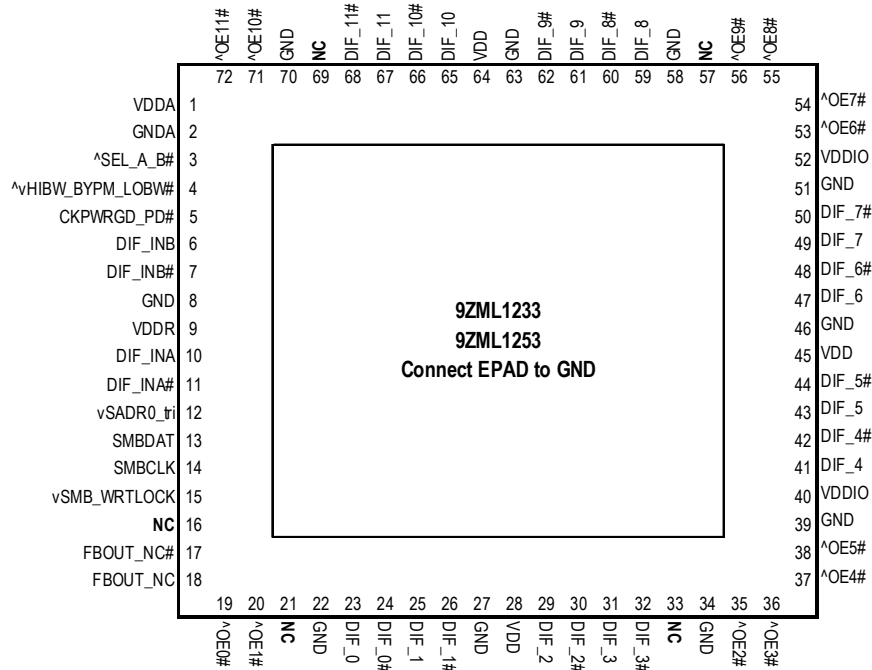

^ prefix indicates internal 120kohm pull-up  
 v prefix indicates internal 120kohm pull-down  
 10 x 10 mm 72-VFQFPN 0.5mm pin pitch

## Pin Descriptions

**Table 1. Pin Descriptions**

Number	Name	Type	Description
1	V <sub>DDA</sub>	Power	Power supply for PLL core.
2	GNDA	GND	Ground pin for the PLL core.
3	^SEL_A_B#	Input	Input to select differential input clock A or differential input clock B. This input has an internal 120kΩ pull-up resistor. 0 = input B selected, 1 = input A selected.
4	^vHIBW_BYPM_LOBW#	Latched In	Tri-level input to select High BW, Bypass or Low BW mode. This pin is biased to V <sub>DD</sub> /2 (Bypass Mode) with internal pull-up/pull-down resistors. See <i>PLL Operating Mode</i> table for details.
5	CKPWRGD_PD#	Input	3.3V input notifies device to sample latched inputs and start up on first high assertion, or exit Power Down Mode on subsequent assertions. Low enters Power Down Mode.
6	DIF_INB	Input	True input of differential clock.
7	DIF_INB#	Input	Complement input of differential clock.
8	GND	GND	Ground pin.
9	V <sub>DDR</sub>	Power	Power supply for differential input clock (receiver). This V <sub>DD</sub> should be treated as an analog power rail and filtered appropriately. Nominally 3.3V.
10	DIF_INA	Input	True input of differential clock.
11	DIF_INA#	Input	Complement input of differential clock.

**Table 1. Pin Descriptions (Cont.)**

Number	Name	Type	Description
12	vSADR0_tri	Input	SMBus address bit. This is a tri-level input that works in conjunction with other SADR pins, if present, to decode SMBus Addresses. It has an internal 120kΩ pull-down resistor. See the <i>SMBus Addressing</i> table.
13	SMBDAT	I/O	Data pin of SMBUS circuitry.
14	SMBCLK	Input	Clock pin of SMBUS circuitry.
15	vSMB_WRTLOCK	Input	This pin prevents SMBus writes when asserted. SMBus reads are not affected. This pin has an internal 120kΩ pull-down. 0 = SMBus writes allows, 1 = SMBus writes blocked.
16	NC	—	No connection.
17	FBOUT_NC#	Output	Complementary half of differential feedback output. This pin should NOT be connected to anything outside the chip. It exists to provide delay path matching to get 0 propagation delay.
18	FBOUT_NC	Output	True half of differential feedback output. This pin should NOT be connected to anything outside the chip. It exists to provide delay path matching to get 0 propagation delay.
19	^OE0#	Input	Active low input for enabling output 0. This pin has an internal 120kΩ pull-up resistor. 1 = disable outputs, 0 = enable outputs.
20	^OE1#	Input	Active low input for enabling output 1. This pin has an internal pull-up resistor. 1 = disable outputs, 0 = enable outputs.
21	NC	—	No connection.
22	GND	GND	Ground pin.
23	DIF_0	Output	HCSL true clock output.
24	DIF_0#	Output	HCSL complementary clock output.
25	DIF_1	Output	HCSL true clock output.
26	DIF_1#	Output	HCSL complementary clock output.
27	GND	GND	Ground pin.
28	VDD	Power	Power supply, nominally 3.3V.
29	DIF_2	Output	HCSL true clock output.
30	DIF_2#	Output	HCSL complementary clock output.
31	DIF_3	Output	HCSL true clock output.
32	DIF_3#	Output	HCSL complementary clock output.
33	NC	—	No connection.
34	GND	GND	Ground pin.
35	^OE2#	Input	Active low input for enabling output 2. This pin has an internal pull-up resistor. 1 = disable outputs, 0 = enable outputs.
36	^OE3#	Input	Active low input for enabling output 3. This pin has an internal pull-up resistor. 1 = disable outputs, 0 = enable outputs.
37	^OE4#	Input	Active low input for enabling output 4. This pin has an internal pull-up resistor. 1 = disable outputs, 0 = enable outputs.

**Table 1. Pin Descriptions (Cont.)**

Number	Name	Type	Description
38	^OE5#	Input	Active low input for enabling output 5. This pin has an internal pull-up resistor. 1 = disable outputs, 0 = enable outputs.
39	GND	GND	Ground pin.
40	V <sub>DDIO</sub>	Power	Power supply for differential outputs.
41	DIF_4	Output	HCSL true clock output.
42	DIF_4#	Output	HCSL complementary clock output.
43	DIF_5	Output	HCSL true clock output.
44	DIF_5#	Output	HCSL complementary clock output.
45	V <sub>DD</sub>	PWR	Power supply, nominally 3.3V.
46	GND	GND	Ground pin.
47	DIF_6	Output	HCSL true clock output.
48	DIF_6#	Output	HCSL complementary clock output.
49	DIF_7	Output	HCSL true clock output.
50	DIF_7#	Output	HCSL complementary clock output.
51	GND	GND	Ground pin.
52	V <sub>DDIO</sub>	Power	Power supply for differential outputs.
53	^OE6#	Input	Active low input for enabling output 6. This pin has an internal pull-up resistor. 1 = disable outputs, 0 = enable outputs.
54	^OE7#	Input	Active low input for enabling output 7. This pin has an internal pull-up resistor. 1 = disable outputs, 0 = enable outputs.
55	^OE8#	Input	Active low input for enabling output 8. This pin has an internal pull-up resistor. 1 = disable outputs, 0 = enable outputs.
56	^OE9#	Input	Active low input for enabling output 9. This pin has an internal pull-up resistor. 1 = disable outputs, 0 = enable outputs.
57	NC	—	No connection.
58	GND	GND	Ground pin.
59	DIF_8	Output	HCSL true clock output.
60	DIF_8#	Output	HCSL complementary clock output.
61	DIF_9	Output	HCSL true clock output.
62	DIF_9#	Output	HCSL complementary clock output.
63	GND	GND	Ground pin.
64	V <sub>DD</sub>	Power	Power supply, nominally 3.3V.
65	DIF_10	Output	HCSL true clock output.
66	DIF_10#	Output	HCSL complementary clock output.
67	DIF_11	Output	HCSL true clock output.
68	DIF_11#	Output	HCSL complementary clock output.

**Table 1. Pin Descriptions (Cont.)**

Number	Name	Type	Description
69	NC	—	No connection.
70	GND	GND	Ground pin.
71	$\wedge$ OE10#	Input	Active low input for enabling output 10. This pin has an internal pull-up resistor. 1 = disable outputs, 0 = enable outputs.
72	$\wedge$ OE11#	Input	Active low input for enabling output 11. This pin has an internal pull-up resistor. 1 = disable outputs, 0 = enable outputs.
73	EPAD	GND	Connect to ground.

## Absolute Maximum Ratings

Stresses above the ratings listed below can cause permanent damage to the 9ZML1233E/9ZML1253E. These ratings, which are standard values for Renesas commercially rated parts, are stress ratings only. Functional operation of the device at these or any other conditions above those indicated in the operational sections of the specifications is not implied. Exposure to absolute maximum rating conditions for extended periods can affect product reliability. Electrical parameters are guaranteed only over the recommended operating temperature range.

**Table 2. Absolute Maximum Ratings**

Parameter	Symbol	Conditions	Minimum	Typical	Maximum	Unit	Notes
Supply Voltage	$V_{DDx}$				3.9	V	1,2
Input Low Voltage	$V_{IL}$		GND-0.5			V	1
Input High Voltage	$V_{IH}$	Except for SMBus interface.			$V_{DD} + 0.5$	V	1,3
Input High Voltage	$V_{IHSMB}$	SMBus clock and data pins.			3.9	V	1
Storage Temperature	$T_s$		-65		150	°C	1
Junction Temperature	$T_j$				125	°C	1
Input ESD Protection	ESD prot	Human Body Model.	2000			V	1

<sup>1</sup> Guaranteed by design and characterization, not 100% tested in production.

<sup>2</sup> Operation under these conditions is neither implied nor guaranteed.

<sup>3</sup> Not to exceed 3.9V.

## Electrical Characteristics

Over specified temperature and voltage ranges unless otherwise indicated; see [Test Loads](#) for loading conditions.

**Table 3. SMBus Parameters**

Parameter	Symbol	Conditions	Minimum	Typical	Maximum	Unit	Notes
SMBus Input Low Voltage	$V_{ILSMB}$				0.8	V	
SMBus Input High Voltage	$V_{IHSMB}$		2.1		$V_{DDSMB}$	V	
SMBus Output Low Voltage	$V_{OLSMB}$	At $I_{PULLUP}$ .			0.4	V	
SMBus Sink Current	$I_{PULLUP}$	At $V_{OL}$ .	4			mA	
Nominal Bus Voltage	$V_{DDSMB}$		2.7		3.6	V	1

**Table 3. SMBus Parameters (Cont.)**

Parameter	Symbol	Conditions	Minimum	Typical	Maximum	Unit	Notes
SCLK/SDATA Rise Time	$t_{RSMB}$	(Max $V_{IL} - 0.15V$ ) to (Min $V_{IH} + 0.15V$ ).			1000	ns	1
SCLK/SDATA Fall Time	$t_{FSMB}$	(Min $V_{IH} + 0.15V$ ) to (Max $V_{IL} - 0.15V$ ).			300	ns	1
SMBus Operating Frequency	$f_{MAXMB}$	Maximum SMBus operating frequency.			400	kHz	5

<sup>1</sup> Guaranteed by design and characterization, not 100% tested in production.

<sup>2</sup> Control input must be monotonic from 20% to 80% of input swing.

<sup>3</sup> Time from deassertion until outputs are > 200mV.

<sup>4</sup> DIF\_IN input.

<sup>5</sup> The differential input clock must be running for the SMBus to be active.

**Table 4. DIF\_IN Clock Input Parameters**

Parameter	Symbol	Conditions	Minimum	Typical	Maximum	Unit	Notes
Input Crossover Voltage	$V_{CROSS}$	Cross over voltage.	150		900	mV	1
Input Swing – DIF_IN	$V_{SWING}$	Differential value.	300			mV	1
Input Slew Rate – DIF_IN	dv/dt	Measured differentially.	0.35		8	V/ns	1,2
Input Leakage Current	$I_{IN}$	$V_{IN} = V_{DD}$ , $V_{IN} = GND$ .	-5		5	$\mu A$	
Input Duty Cycle	$d_{tin}$	Measurement from differential waveform.	45		55	%	1
Input Jitter –Cycle to Cycle	$J_{DIFIn}$	Differential measurement.	0		125	ps	1

<sup>1</sup> Guaranteed by design and characterization, not 100% tested in production.

<sup>2</sup> Slew rate measured through  $\pm 75mV$  window centered around differential zero.

**Table 5. Input/Supply/Common Parameters**

Parameter	Symbol	Conditions	Minimum	Typical	Maximum	Unit	Notes
Supply Voltage	$V_{DDX}$	Supply voltage for core and analog.	3.135	3.3	3.465	V	
	$V_{DDIO}$	Supply voltage for differential outputs.	3.135	3.3	3.465	V	
Ambient Operating Temperature	$T_{AMB}$	Industrial range.	-40		85	$^{\circ}C$	
Input High Voltage	$V_{IH}$	Single-ended inputs, except SMBus, tri-level inputs.	2		$V_{DD} + 0.3$	V	
Input Low Voltage	$V_{IL}$	Single-ended inputs, except SMBus, tri-level inputs.	GND - 0.3		0.8	V	
Input High Voltage	$V_{IH}$	Tri-level inputs (“_tri” suffix).	2.2		$V_{DD} + 0.3$	V	
Input Mid Voltage	$V_{IM}$	Tri-level inputs (“_tri” suffix).	1.2	$V_{DD}/2$	1.8	V	
Input Low Voltage	$V_{IL}$	Tri-level inputs (“_tri” suffix).	GND - 0.3		0.8	V	
Input Current	$I_{IN}$	Single-ended inputs, $V_{IN} = GND$ , $V_{IN} = V_{DDX}$ .	-5		5	$\mu A$	
	$I_{INP}$	Single-ended inputs $V_{IN} = 0V$ ; Inputs with internal pull-up resistors. $V_{IN} = V_{DD}$ ; Inputs with internal pull-down resistors.	-100		100	$\mu A$	

**Table 5. Input/Supply/Common Parameters (Cont.)**

Parameter	Symbol	Conditions	Minimum	Typical	Maximum	Unit	Notes
Input Frequency	F <sub>IBYP</sub>	V <sub>DD</sub> = 3.3V, Bypass Mode.	1		400	MHz	
	F <sub>IPLL</sub>	V <sub>DD</sub> = 3.3V, 100MHz PLL Mode.	98.5	100.00	102	MHz	5
Pin Inductance	L <sub>pin</sub>				7	nH	1
Capacitance	C <sub>IN</sub>	Logic Inputs, except DIF_IN.	1.5		5	pF	1
	C <sub>INDIF_IN</sub>	DIF_IN differential clock inputs.	1.5		2.7	pF	1,4
	C <sub>OUT</sub>	Output pin capacitance.			6	pF	1
Clk Stabilization	t <sub>STAB</sub>	From V <sub>DD</sub> power-up and after input clock stabilization or deassertion of PD# to 1st clock.		1.2	1.8	ms	1,2
Input SS Modulation Frequency PCIe	f <sub>MODINPCIe</sub>	Allowable frequency for PCIe applications (triangular modulation).	30	31.6	33	kHz	
OE# Latency	t <sub>LATOE#</sub>	DIF start after OE# assertion. DIF stop after OE# deassertion.	4	5	10	clocks	1,2,3
Tdrive_PD#	t <sub>DRVPD</sub>	DIF output enable after PD# deassertion.		85	300	μs	1,3
Tfall	t <sub>F</sub>	Fall time of control inputs.			5	ns	2
Trise	t <sub>R</sub>	Rise time of control inputs.			5	ns	2

<sup>1</sup> Guaranteed by design and characterization, not 100% tested in production.

<sup>2</sup> Control input must be monotonic from 20% to 80% of input swing.

<sup>3</sup> Time from deassertion until outputs are > 200mV, PLL Mode.

<sup>4</sup> DIF\_IN input.

<sup>5</sup> This parameter reflects the operating range after locking to a 100MHz input.

**Table 6. Current Consumption**

Parameter	Symbol	Conditions	Minimum	Typical	Maximum	Unit	Notes
Operating Supply Current	I <sub>DDX</sub>	All other V <sub>DD</sub> pins, all outputs at 100MHz, C <sub>L</sub> = 2pF; Z <sub>o</sub> = 85Ω.		22	30	mA	
	I <sub>DDA+R</sub>	V <sub>DDA</sub> + V <sub>DDR</sub> pins, all outputs at 100MHz, C <sub>L</sub> = 2pF; Z <sub>o</sub> = 85Ω.		56	65	mA	1
	I <sub>DDO</sub>	V <sub>DDIO</sub> pins, all outputs at 100MHz, C <sub>L</sub> = 2pF; Z <sub>o</sub> = 85Ω.		84	100	mA	
Power Down Current	I <sub>DDX</sub>	All other V <sub>DD</sub> pins, all outputs Low/Low.		0.9	2	mA	1
	I <sub>DDA+R</sub>	V <sub>DDA</sub> + V <sub>DDR</sub> pins, all outputs Low/Low.		4.3	6	mA	1
	I <sub>DDO</sub>	V <sub>DDIO</sub> pins, all outputs Low/Low.		0.1	0.2	mA	1

<sup>1</sup> Includes V<sub>DDR</sub> if applicable.

**Table 7. Skew and Differential Jitter Parameters**

Parameter	Symbol	Conditions	Minimum	Typical	Maximum	Unit	Notes
CLK_IN, DIF[x:0]	$t_{\text{SKEW\_PLL}}$	Input-to-output skew in PLL Mode at 100MHz, nominal temperature and voltage.	-100	-4	100	ps	1,2,4,5,6,8
CLK_IN, DIF[x:0]	$t_{\text{PD\_BYP}}$	Input-to-output skew in Bypass Mode at 100MHz, nominal temperature and voltage.	2.2	2.9	3.6	ns	1,2,3,8
CLK_IN, DIF[x:0]	$t_{\text{DSPO\_PLL}}$	Input-to-output skew variation in PLL Mode at 100MHz, across voltage and temperature.	-50	0.0	50	ps	1,2,3,8
CLK_IN, DIF[x:0]	$t_{\text{DSPO\_BYP}}$	Input-to-output skew variation in Bypass Mode at 100MHz, across voltage and temperature, $T_{\text{AMB}} = 0$ to $+70^{\circ}\text{C}$ , default slew rate.	-250	0.0	250	ps	1,2,3,8
		Input-to-output skew variation in Bypass Mode at 100MHz, across voltage and temperature, $T_{\text{AMB}} = -40$ to $+85^{\circ}\text{C}$ , default slew rate.	-350	0.0	350	ps	1,2,3,8
DIF[x:0]	$t_{\text{SKEW\_ALL}}$	Output-to-output skew across all outputs, common to PLL and Bypass Mode, at 100MHz, default slew rate.		30	50	ps	1,2,3,8
PLL Jitter Peaking	$j_{\text{peak-hibw}}$	LOBW#_BYPASS_HIBW = 1.	0	1.3	2.5	dB	7,8
PLL Jitter Peaking	$j_{\text{peak-lobw}}$	LOBW#_BYPASS_HIBW = 0.	0	1.3	2	dB	7,8
PLL Bandwidth	$\text{pll}_{\text{HIBW}}$	LOBW#_BYPASS_HIBW = 1.	2	2.6	4	MHz	8,9
PLL Bandwidth	$\text{pll}_{\text{LOBW}}$	LOBW#_BYPASS_HIBW = 0.	0.7	1.0	1.4	MHz	8,9
Duty Cycle	$t_{\text{DC}}$	Measured differentially, PLL Mode.	45	50	55	%	1
Duty Cycle Distortion	$t_{\text{DCD}}$	Measured differentially, Bypass Mode at 100MHz.	-1	-0.2	0	%	1,10
Jitter, Cycle to Cycle	$t_{\text{jyc-cyc}}$	PLL Mode.		13	50	ps	1,11
		Additive jitter in Bypass Mode.		0.2	5	ps	1,11

<sup>1</sup> Measured into fixed 2pF load cap. Input to output skew is measured at the first output edge following the corresponding input.

<sup>2</sup> Measured from differential cross-point to differential cross-point. This parameter can be tuned with external feedback path, if present.

<sup>3</sup> All Bypass Mode input-to-output specs refer to the timing between an input edge and the specific output edge created by it.

<sup>4</sup> This parameter is deterministic for a given device.

<sup>5</sup> Measured with scope averaging on to find mean value.

<sup>6</sup> This value is programmable.

<sup>7</sup> Measured as maximum pass band gain. At frequencies within the loop BW, highest point of magnification is called PLL jitter peaking.

<sup>8</sup> Guaranteed by design and characterization, not 100% tested in production.

<sup>9</sup> Measured at 3db down or half power point.

<sup>10</sup> Duty cycle distortion is the difference in duty cycle between the output and the input clock when the device is operated in Bypass Mode.

<sup>11</sup> Measured from differential waveform.

**Table 8. DIF HCSL/LP-HCSL Outputs**

Parameter	Symbol	Conditions	Minimum	Typical	Maximum	Industry Limits	Unit	Notes
Slew Rate	dV/dt	Scope averaging on.	2.0	2.8	4.0	0.6 – 4.0	V/ns	1,2,3
Slew Rate Matching	$\Delta$ dV/dt	Slew rate matching, scope averaging on.		4	15	20	%	1,2,4,7
Maximum Voltage	V <sub>MAX</sub>	Measurement on single-ended signal using absolute value (scope averaging off).	660	794	870	1150	mV	7,8
Minimum Voltage	V <sub>MIN</sub>		-111	-49		-300		7,8
Crossing Voltage (abs)	V <sub>CROSS_ABS</sub>	Scope averaging off.	302	367	453	250 – 550	mV	1,5,7
Crossing Voltage (var)	$\Delta$ -V <sub>CROSS</sub>	Scope averaging off.		32	74	140	mV	1,6,7

<sup>1</sup> Guaranteed by design and characterization, not 100% tested in production.

<sup>2</sup> Measured from differential waveform.

<sup>3</sup> Slew rate is measured through the V<sub>SWING</sub> voltage range centered around differential 0 V. This results in a  $\pm$ 150mV window around differential 0V.

<sup>4</sup> Matching applies to rising edge rate for Clock and falling edge rate for Clock#. It is measured using a  $\pm$ 75mV window centered on the average cross point where Clock rising meets Clock# falling. The median cross point is used to calculate the voltage thresholds the oscilloscope is to use for the edge rate calculations.

<sup>5</sup> V<sub>CROSS</sub> is defined as voltage where Clock = Clock# measured on a component test board and only applies to the differential rising edge (i.e. Clock rising and Clock# falling).

<sup>6</sup> The total variation of all V<sub>CROSS</sub> measurements in any particular system. Note that this is a subset of V<sub>CROSS\_MIN/MAX</sub> (V<sub>CROSS</sub> absolute) allowed. The intent is to limit V<sub>CROSS</sub> induced modulation by setting  $\Delta$ -V<sub>CROSS</sub> to be smaller than V<sub>CROSS</sub> absolute.

<sup>7</sup> At default SMBus settings.

<sup>8</sup> If driving a receiver with input terminations, the V<sub>MAX</sub> and V<sub>MIN</sub> values will be halved.

**Table 9. Filtered Phase Jitter Parameters – PCIe Common Clocked (CC) Architectures**

Parameter	Symbol	Conditions	Minimum	Typical	Maximum	Industry Limits	Unit	Notes
Phase Jitter, PLL Mode	t <sub>jphPCleG1-CC</sub>	PCIe Gen1		13	30	86	ps (p-p)	1,2,3,6
	t <sub>jphPCleG2-CC</sub>	PCIe Gen2 Low Band 10kHz < f < 1.5MHz (PLL BW of 5–16MHz or 8–16MHz, CDR = 5MHz).		0.25	0.7	3	ps (rms)	1,2,6
		PCIe Gen2 High Band 1.5MHz < f < Nyquist (50MHz) (PLL BW of 5–16MHz or 8–16MHz, CDR = 5MHz).		1.00	1.5	3.1	ps (rms)	1,2,6
	t <sub>jphPCleG3-CC</sub>	PCIe Gen3 (PLL BW of 2–4MHz or 2–5MHz, CDR = 10MHz).		0.24	0.35	1	ps (rms)	1,2,6
	t <sub>jphPCleG4-CC</sub>	PCIe Gen4 (PLL BW of 2–4MHz or 2–5MHz, CDR = 10MHz).		0.24	0.35	0.5	ps (rms)	1,2,6

**Table 9. Filtered Phase Jitter Parameters – PCIe Common Clocked (CC) Architectures (Cont.)**

Parameter	Symbol	Conditions	Minimum	Typical	Maximum	Industry Limits	Unit	Notes
Additive Phase Jitter, Bypass Mode	$t_{jphPCleG1-CC}$	PCIe Gen1		0.0	0.05	Not Applicable	ps (p-p)	1,2,3, 4,6
	$t_{jphPCleG2-CC}$	PCIe Gen2 Low Band 10kHz < f < 1.5MHz (PLL BW of 5–16MHz or 8–16MHz, CDR = 5MHz).		0.00	0.05		ps (rms)	1,2,3, 4,6
		PCIe Gen2 High Band 1.5MHz < f < Nyquist (50MHz) (PLL BW of 5–16MHz or 8–16MHz, CDR = 5MHz).		0.00	0.05		ps (rms)	1,2,3, 4,6
	$t_{jphPCleG3-CC}$	PCIe Gen3 (PLL BW of 2–4MHz or 2–5MHz, CDR = 10MHz).		0.00	0.05		ps (rms)	1,2,3, 4,6
	$t_{jphPCleG4-CC}$	PCIe Gen4 (PLL BW of 2–4MHz or 2–5MHz, CDR = 10MHz).		0.00	0.05		ps (rms)	1,2,3, 4,6

**Table 10. Filtered Phase Jitter Parameters – PCIe Independent Reference (IR) Architectures**

Parameter	Symbol	Conditions	Minimum	Typical	Maximum	Industry Limits	Unit	Notes
Phase Jitter, PLL Mode	$t_{jphPCleG2-SRIS}$	PCIe Gen2 (PLL BW of 16MHz, CDR = 5MHz).		0.8	1.2	2	ps (rms)	1,2,5
	$t_{jphPCleG3-SRIS}$	PCIe Gen3 (PLL BW of 2–4MHz, CDR = 10MHz).		0.64	0.68	0.7	ps (rms)	1,2,5
Additive Phase Jitter, Bypass Mode	$t_{jphPCleG2-SRIS}$	PCIe Gen2 (PLL BW of 16MHz, CDR = 5MHz).		0.00	0.02	Not Applicable	ps (rms)	2,4,5
	$t_{jphPCleG3-SRIS}$	PCIe Gen3 (PLL BW of 2–4MHz, CDR = 10MHz).		0.00	0.02		ps (rms)	2,4,5

Notes for PCIe Filtered Phase Jitter tables:

- <sup>1</sup> Applies to all differential outputs when driven by 9SQL495x or equivalent, guaranteed by design and characterization.
- <sup>2</sup> Calculated from Intel-supplied clock jitter tool, when driven by 9SQL495x or equivalent with spread on and off.
- <sup>3</sup> Sample size of at least 100K cycles. This figure extrapolates to 108ps pk-pk at 1M cycles for a BER of  $1^{-12}$ .
- <sup>4</sup> For RMS values, additive jitter is calculated by solving the following equation for b [ $b = \sqrt{c^2 - a^2}$ ] where “a” is rms input jitter and “c” is rms total jitter.
- <sup>5</sup> IR is the new name for Separate Reference Independent Spread (SRIS) and Separate Reference no Spread (SRNS) PCIe clock architectures. According to the PCIe Base Specification Rev4.0 version 0.7 draft, the jitter transfer functions and corresponding jitter limits are not defined for the IR clock architecture. Widely accepted industry limits using widely accepted industry filters are used to populate this table. There are no accepted filters or limits for IR clock architectures at PCIe Gen1 or Gen4 data rates.

**Table 11. Filtered Phase Jitter Parameters – QPI/UPI**

Parameter	Symbol	Conditions	Minimum	Typical	Maximum	Industry Limits	Unit	Notes
Phase Jitter, PLL Mode	t <sub>jphQPI_UPI</sub>	QPI and UPI (100MHz or 133MHz, 4.8Gb/s, 6.4Gb/s 12UI).		0.15	0.3	0.5	ps (rms)	1,2
		QPI and UPI (100MHz, 8.0Gb/s, 12UI).		0.08	0.1	0.3	ps (rms)	1,2
		QPI and UPI (100MHz, ≥ 9.6Gb/s, 12UI).		0.07	0.1	0.2	ps (rms)	1,2
	t <sub>jphIF-UPI</sub>	IF-UPI		0.1 0.17	0.15 0.2	1	ps (rms)	1,4,5
Additive Phase Jitter, Bypass Mode	t <sub>jphQPI_UPI</sub>	QPI and UPI (100MHz or 133MHz, 4.8Gb/s, 6.4Gb/s 12UI).		0.00	0.03	Not Applicable	ps (rms)	1,2,3
		QPI and UPI (100MHz, 8.0Gb/s, 12UI).		0.02	0.07		ps (rms)	1,2,3
		QPI and UPI (100MHz, ≥ 9.6Gb/s, 12UI).		0.02	0.06		ps (rms)	1,2,3
	t <sub>jphIF-UPI</sub>	IF-UPI		0.06	0.08		ps (rms)	1,4

<sup>1</sup> Applies to all differential outputs, guaranteed by design and characterization.

<sup>2</sup> Calculated from Intel-supplied clock jitter tool, when driven by 9SQL495x or equivalent with spread on and off.

<sup>3</sup> Additive jitter for RMS values is calculated by solving for b [ $b = \sqrt{c^2 - a^2}$ ] where “a” is rms input jitter and “c” is rms total jitter.

<sup>4</sup> Calculated from phase noise analyzer when driven by Wenzel Associates source with Intel-specified brick-wall filter applied.

<sup>5</sup> Top number is when the buffer is in Low BW mode, bottom number is when the buffer is in High BW mode.

**Table 12. Unfiltered Phase Jitter Parameters – 12kHz to 20MHz**

Parameter	Symbol	Conditions	Minimum	Typical	Maximum	Industry Limits	Unit	Notes
Phase Jitter, PLL Mode	t <sub>jph12k-20MHi</sub>	PLL High BW, SSC Off, 100MHz.		171	250	Not applicable	fs (rms)	1,2
Phase Jitter, PLL Mode	t <sub>jph12k-20MLo</sub>	PLL Low BW, SSC Off, 100MHz.		183	250		fs (rms)	1,2
Additive Phase Jitter, Bypass Mode	t <sub>jph12k-20MBy</sub>	Bypass Mode, SSC Off, 100MHz.		109	150		fs (rms)	1,2,3

<sup>1</sup> Applies to all outputs when driven by Wenzel clock source.

<sup>2</sup> 12kHz to 20MHz brick wall filter.

<sup>3</sup> For RMS values, additive jitter is calculated by solving for b [ $a^2 + b^2 = c^2$ ] where “a” is rms input jitter and “c” is rms total jitter.

## Power Management

Inputs		Control Bits	Outputs		PLL State
CKPWRGD_PD#	DIF_IN	SMBus EN bit	DIF_x	FBOUT_NC	
0	X	X	Low/Low	Low/Low	Off
1	Running	0	Low/Low	Running	On
		1	Running	Running	On

## Power Connections (9ZML12xxE)

Pin Number			Description
V <sub>DD</sub>	V <sub>DDIO</sub>	GND	
1		2	Analog PLL
9		8	Analog input
28, 45, 64	40, 52	22, 27, 34, 39, 46, 51, 58, 63, 70	DIF clocks

## Power Connections (for pin-compatibility with 9ZML12xxB)

Pin Number			Description
V <sub>DD</sub>	V <sub>DDIO</sub>	GND	
1		2	Analog PLL
9		8	Analog input
28, 45, 64	21, 33, 40, 52, 57, 69	16, 22, 27, 34, 39, 46, 51, 58, 63, 70	DIF clocks

## PLL Operating Mode

HIBW_BYPM_LOBW#	Byte0[7:6]
Low (PLL Low BW)	00
Mid (Bypass)	01
High (PLL High BW)	11

Note: PLL is off in Bypass Mode.

## Skew Programming

Skew[2:0]	Skew Steps	Skew (ps)
000	0	0
001	1	-416.67
010	2	-833.33
011	3	-1250.00
100	4	-1666.67
101	5	-2083.33
110	6	-2500.00
111	7	-2916.67

**Figure 1. Skew Diagram**

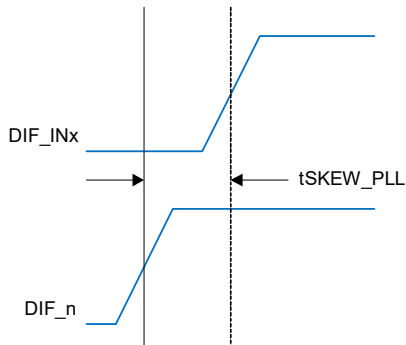

## Test Loads

Low-Power HCSL Output Test Load  
(standard PCIe source-terminated test load)

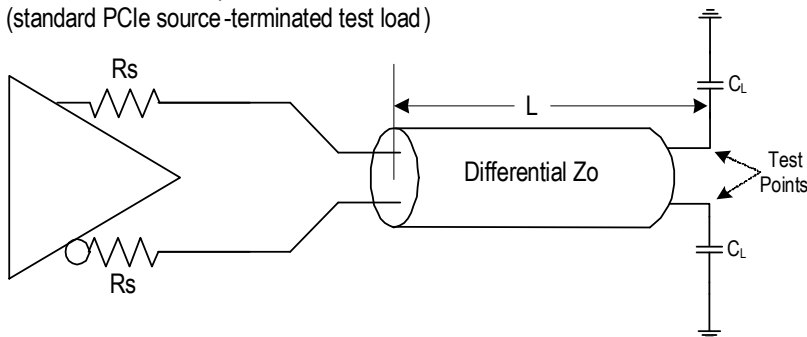

**Table 13. Parameters for Low-Power HCSL Output Test Load**

Device	$R_s$ ( $\Omega$ )	$Z_o$ ( $\Omega$ )	L (inches)	$C_L$ (pF)
9ZML123x	27	85	12	2
9ZML123x	33	100	12	2
9ZML125x *	Internal	85	12	2
9ZML125x *	7.5	100	12	2

\* Contact factory for versions of this device with  $Z_o = 100\Omega$ .

## Alternate Terminations

The LP-HCSL can easily drive other logic families. See [“AN-891 Driving LVPECL, LVDS, and CML Logic with “Universal” Low-Power HCSL Outputs”](#) for details.

## Clock Periods

**Table 14. Clock Periods – Differential Outputs with Spread Spectrum Disabled**

SSC On	Center Frequency MHz	Measurement Window							Unit	Notes
		1 Clock	1µs	0.1s	0.1s	0.1s	1µs	1 Clock		
		-c2jitter Abs Per Minimum	-SSC Short-Term Average Minimum	-ppm Long-Term Average Minimum	0 ppm Period Nominal	+ppm Long-Term Average Maximum	+SSC Short-Term Average Maximum	+c2jitter Abs Per Maximum		
DIF	100.00	9.94900	—	9.99900	10.00000	10.00100	—	10.05100	ns	1,2,3

**Table 15. Clock Periods – Differential Outputs with Spread Spectrum Enabled**

SSC On	Center Frequency MHz	Measurement Window							Unit	Notes
		1 Clock	1µs	0.1s	0.1s	0.1s	1µs	1 Clock		
		-c2jitter Abs Per Minimum	-SSC Short-Term Average Minimum	-ppm Long-Term Average Minimum	0 ppm Period Nominal	+ppm Long-Term Average Maximum	+SSC Short-Term Average Maximum	+c2jitter Abs Per Maximum		
DIF	99.75	9.94906	9.99906	10.02406	10.02506	10.02607	10.05107	10.10107	ns	1,2,3

<sup>1</sup> Guaranteed by design and characterization, not 100% tested in production.

<sup>2</sup> All Long Term Accuracy specifications are guaranteed with the assumption that the input clock complies with CK420BQ accuracy requirements ( $\pm 100$ ppm). The buffer itself does not contribute to ppm error.

<sup>3</sup> Driven by SRC output of main clock, 100MHz PLL Mode or Bypass Mode.

## General SMBus Serial Interface Information

### How to Write

- Controller (host) sends a start bit
- Controller (host) sends the write address
- Renesas clock will **acknowledge**
- Controller (host) sends the beginning byte location = N
- Renesas clock will **acknowledge**
- Controller (host) sends the byte count = X
- Renesas clock will **acknowledge**
- Controller (host) starts sending Byte N through Byte N+X-1
- Renesas clock will **acknowledge** each byte **one at a time**
- Controller (host) sends a stop bit

Index Block Write Operation		
Controller (Host)		Renesas (Slave/Receiver)
T	starT bit	
Slave Address		
WR	WRite	
		ACK
Beginning Byte = N		
		ACK
Data Byte Count = X		
		ACK
Beginning Byte N		
		ACK
O		O
O		O
O		O
Byte N + X - 1		
		ACK
P	stoP bit	

### 9ZML1233E/9ZML1253E SMBus Addressing

SMB_A0_tri	SMBus Address (Read/Write bit = 0)
0	D8
M	DA
1	DE

### How to Read

- Controller (host) will send a start bit
- Controller (host) sends the write address
- Renesas clock will **acknowledge**
- Controller (host) sends the beginning byte location = N
- Renesas clock will **acknowledge**
- Controller (host) will send a separate start bit
- Controller (host) sends the read address
- Renesas clock will **acknowledge**
- Renesas clock will send the data byte count = X
- Renesas clock sends Byte N+X-1
- Renesas clock sends **Byte 0 through Byte X (if X<sub>(H)</sub> was written to Byte 8)**
- Controller (host) will need to acknowledge each byte
- Controller (host) will send a not acknowledge bit
- Controller (host) will send a stop bit

Index Block Read Operation		
Controller (Host)		Renesas
T	starT bit	
Slave Address		
WR	WRite	
		ACK
Beginning Byte = N		
		ACK
RT	Repeat starT	
Slave Address		
RD	ReaD	
		ACK
		Data Byte Count=X
ACK		
		Beginning Byte N
ACK		
O		O
O		O
O		O
		Byte N + X - 1
N	Not acknowledge	
P	stoP bit	

**SMBus Table: PLL Mode and Frequency Select Register**

Byte 0	Name	Control Function	Type	0	1	Default
Bit 7	PLL Mode bit [1]	PLL Operating Mode Rd back 1	R	See PLL Operating Mode table		Latch
Bit 6	PLL Mode bit [0]	PLL Operating Mode Rd back 0	R			Latch
Bit 5	SEL_A_B#	Input Select Readback	R	DIF_INB	DIF_INA	Pin
Bit 4	SMB_WRTLOCK_RB	SMB_WRTLOCK_Readback	R	Pin is Low	Pin is High	Pin
Bit 3	PLL_InSEL_SW_EN	Enable S/W control of PLL BW and Input select	RW	Pin Control	SMBus Control	0
Bit 2	PLL Mode bit [1]	PLL Operating Mode 1	RW	See PLL Operating Mode table <sup>1</sup>		1
Bit 1	PLL Mode bit [0]	PLL Operating Mode 1	RW			1
Bit 0	SEL_A_B#	Input Select Status or Control	RW	DIF_INB	DIF_INA	1

**Note:** Setting bit 3 to '1' allows the user to override the latch value from pin 5 via use of bits 2 and 1. The system may require a warm system reset if the user changes these bits. The clock itself does not require a reset. Setting bit 3 to a '1' also allows the user to use bit 0 to control the input select.

**SMBus Table: Output Disable Register**

Byte 1	Name	Control Function	Type	0	1	Default
Bit 7	DIF_7_En	Output Control overrides OE# pin	RW	Low/Low	Pin Control	1
Bit 6	DIF_6_En	Output Control overrides OE# pin	RW			1
Bit 5	DIF_5_En	Output Control overrides OE# pin	RW			1
Bit 4	DIF_4_En	Output Control overrides OE# pin	RW			1
Bit 3	DIF_3_En	Output Control overrides OE# pin	RW			1
Bit 2	DIF_2_En	Output Control overrides OE# pin	RW			1
Bit 1	DIF_1_En	Output Control overrides OE# pin	RW			1
Bit 0	DIF_0_En	Output Control overrides OE# pin	RW			1

**SMBus Table: Output Control Register**

Byte 2	Name	Control Function	Type	0	1	Default
Bit 7	Reserved					0
Bit 6	Reserved					0
Bit 5	Reserved					0
Bit 4	Reserved					0
Bit 3	DIF_11_En	Output Control overrides OE# pin	RW	Low/Low	Pin Control	1
Bit 2	DIF_10_En	Output Control overrides OE# pin	RW			1
Bit 1	DIF_9_En	Output Control overrides OE# pin	RW			1
Bit 0	DIF_8_En	Output Control overrides OE# pin	RW			1

**SMBus Table: Reserved Register**

Byte 3	Name	Control Function	Type	0	1	Default
Bit 7		Reserved				0
Bit 6		Reserved				0
Bit 5		Reserved				0
Bit 4		Reserved				0
Bit 3		Reserved				0
Bit 2		Reserved				0
Bit 1		Reserved				0
Bit 0		Reserved				0

**SMBus Table: Reserved Register**

Byte 4	Name	Control Function	Type	0	1	Default
Bit 7		Reserved				0
Bit 6		Reserved				0
Bit 5		Reserved				0
Bit 4		Reserved				0
Bit 3		Reserved				0
Bit 2		Reserved				0
Bit 1		Reserved				0
Bit 0		Reserved				0

**SMBus Table: Vendor & Revision ID Register**

Byte 5	Name	Control Function	Type	0	1	Default
Bit 7	RID3	REVISION ID	R	E rev = 0100		0
Bit 6	RID2		R			1
Bit 5	RID1		R			0
Bit 4	RID0		R			0
Bit 3	VID3	VENDOR ID	R	—	—	0
Bit 2	VID2		R	—	—	0
Bit 1	VID1		R	—	—	0
Bit 0	VID0		R	—	—	1

**SMBus Table: Device ID**

Byte 6	Name	Control Function	Type	0	1	Default
Bit 7	Device ID 7 (MSB)		R	9ZML1233 = ED 9ZML1253 = FD		1
Bit 6	Device ID 6		R			1
Bit 5	Device ID 5		R			1
Bit 4	Device ID 4		R			X
Bit 3	Device ID 3		R			1
Bit 2	Device ID 2		R			1
Bit 1	Device ID 1		R			0
Bit 0	Device ID 0		R			X

**SMBus Table: Byte Count Register**

Byte 7	Name	Control Function	Type	0	1	Default
Bit 7	Reserved					0
Bit 6	Reserved					0
Bit 5	Reserved					0
Bit 4	BC4	Writing to this register configures how many bytes will be read back.	RW	Default value is 8 hex, so 9 bytes (0 to 8) will be read back by default.		0
Bit 3	BC3		RW			1
Bit 2	BC2		RW			0
Bit 1	BC1		RW			0
Bit 0	BC0		RW			0

**SMBus Table: Output Skew Register A (when Input Clock A is selected)**

Byte 8	Name	Control Function	Type	0	1	Default
Bit 7	Reserved					0
Bit 6	Reserved					0
Bit 5	Reserved					0
Bit 4	Reserved					0
Bit 3	Reserved					0
Bit 2	I2O_FB_ASkew2	Channel A Output delay programming (early)	RW	Binary value of number of VCO periods that outputs will be pulled earlier than input.		0
Bit 1	I2O_FB_ASkew1		RW			0
Bit 0	I2O_FB_ASkew0		RW			0

**Note:** For example, at 2.4GHz, each VCO period is 416.7ps and there are 24 VCO periods in a 100MHz output. Each write to bits [2:0] will pull the output a early by that number of VCO periods. Writing “110” four times would pull the output back in phase with the input. Writing “001” twice will accomplish the same result as writing “010” once - pulling the output 2 VCO periods earlier.

**SMBus Table: Output Skew Register A (when Input Clock B is selected)**

Byte 9	Name	Control Function	Type	0	1	Default
Bit 7	Reserved					0
Bit 6	Reserved					0
Bit 5	Reserved					0
Bit 4	Reserved					0
Bit 3	Reserved					0
Bit 2	I2O_FB_BSkew2	Channel B Output delay programming (early)	RW	Binary value of number of VCO periods that outputs will be earlier than input. Default is 0.		0
Bit 1	I2O_FB_BSkew1		RW			0
Bit 0	I2O_FB_BSkew0		RW			0

**Note:** For example, at 2.4GHz, each VCO period is 416.7ps and there are 24 VCO periods in a 100MHz output. Each write to bits [2:0] will pull the output early by that number of VCO periods. Writing “110” four times would pull the output back in phase with the input. Writing “001” twice will accomplish the same result as writing “010” once - pulling the output 2 VCO periods earlier.

**Package Outline Drawings**

The package outline drawings are located at the end of this document and are accessible from the Renesas website (see [Ordering Information](#) for POD links). The package information is the most current data available and is subject to change without revision of this document.

**Ordering Information**

Orderable Part Number	Package	Carrier Type	Temperature
9ZML1233EKILF	10 × 10 mm, 0.5mm pitch <a href="#">72-VFQFPN</a>	Tray	-40° to +85°C
9ZML1233EKILFT		Tape and Reel	-40° to +85°C
9ZML1253EKILF		Tray	-40° to +85°C
9ZML1253EKILFT		Tape and Reel	-40° to +85°C

“LF” designates PB-free configuration, RoHS compliant.

“E” is the device revision designator (will not correlate with the datasheet revision).

**Marking Diagrams**

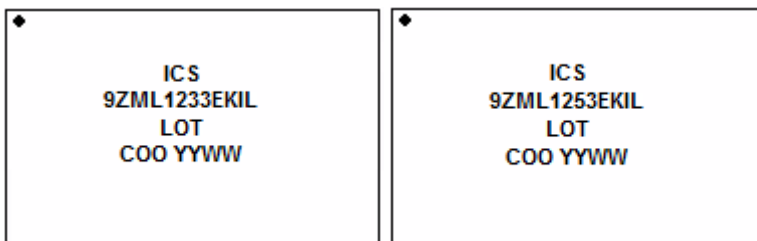

- Line 2: part number.
- Line 3: “LOT” denotes the lot number.
- Line 4: “COO” denotes country of origin; “YYWW” denotes the last two digits of the year and work week the part was assembled.

## Revision History

Revision Date	Description of Change
May 12, 2021	Updates to Byte 0, bit 0, bit 4, and bit 5 defaults.
May 4, 2021	<ul style="list-style-type: none"> <li>▪ Updated Byte0 and footnote.</li> <li>▪ Updated marking diagrams and notes.</li> <li>▪ Updated Package Outline Drawings section.</li> </ul>
April 12, 2018	Updated absolute maximum supply voltage rating and VIHSMB to 3.9V.
December 1, 2017	Removed "5V tolerant" reference in pins 13 and 14 descriptions.
May 19, 2017	Corrected typos in orderable part numbers.
May 11, 2017	<ul style="list-style-type: none"> <li>▪ Updated package outline drawings to latest version.</li> <li>▪ Updated Byte 6 IDs.</li> </ul>
April 27, 2017	<ul style="list-style-type: none"> <li>▪ Updated Phase Jitter, PLL Mode IF-UPI typical and maximum values.</li> </ul>
April 21, 2017	<ul style="list-style-type: none"> <li>▪ Update Features and Key Specifications.</li> <li>▪ Updated PCIe Common Clocked, PCIe Separate Clocked, and QPI/UPI to latest format, added IF-UPI spec to QPI/UPI tables.</li> <li>▪ Updated Test Loads drawing to latest version.</li> <li>▪ Corrected SMBus Addressing table for 1233/1253.</li> </ul>
April 11, 2017	<ul style="list-style-type: none"> <li>▪ Reverted back to original Device ID Scheme, byte 6 updated accordingly: 9ZML1233 = ED 9ZML1253 = FD</li> </ul>
January 31, 2017	Initial release.

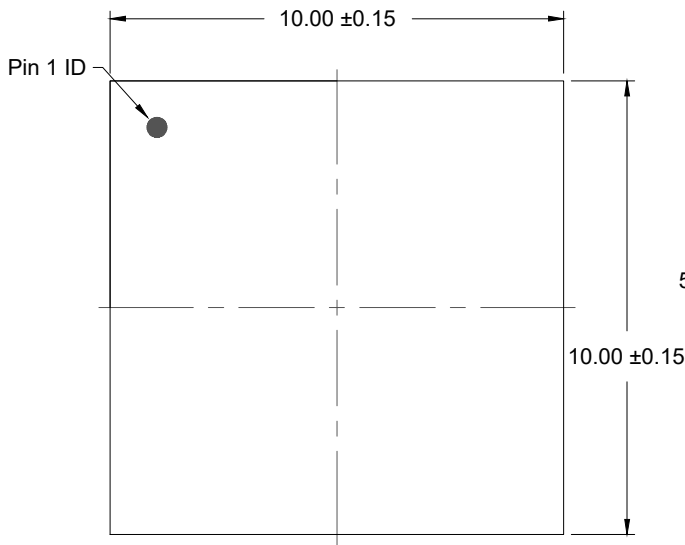

TOP VIEW

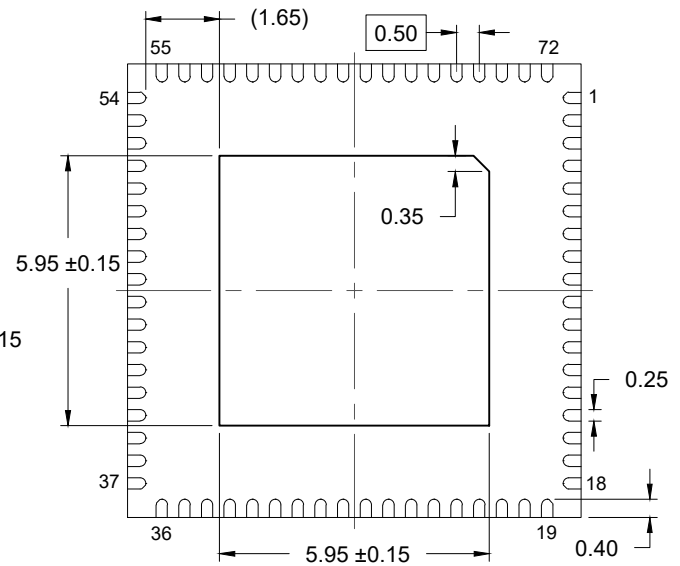

BOTTOM VIEW

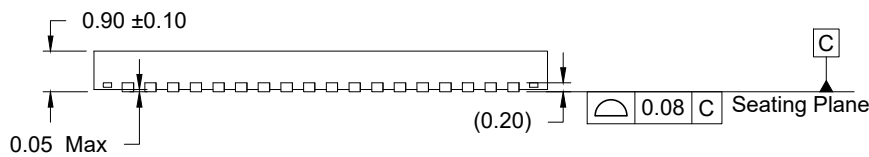

SIDE VIEW

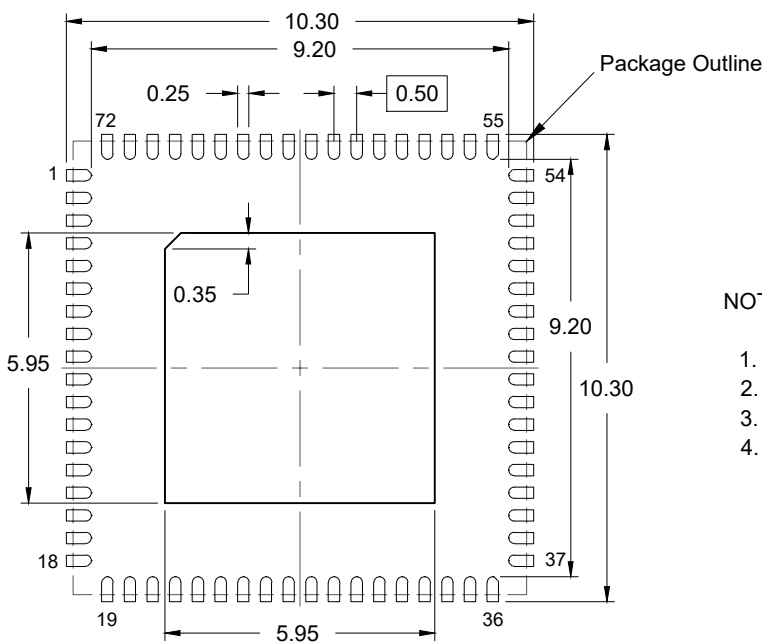

RECOMMENDED LAND PATTERN  
(PCB Top View, NSMD Design)

NOTES:

1. JEDEC compatible.
2. All dimensions are in mm and angles are in degrees.
3. Use  $\pm 0.05$  mm for the non-toleranced dimensions.
4. Numbers in ( ) are for references only.

## IMPORTANT NOTICE AND DISCLAIMER

RENESAS ELECTRONICS CORPORATION AND ITS SUBSIDIARIES (“RENESAS”) PROVIDES TECHNICAL SPECIFICATIONS AND RELIABILITY DATA (INCLUDING DATASHEETS), DESIGN RESOURCES (INCLUDING REFERENCE DESIGNS), APPLICATION OR OTHER DESIGN ADVICE, WEB TOOLS, SAFETY INFORMATION, AND OTHER RESOURCES “AS IS” AND WITH ALL FAULTS, AND DISCLAIMS ALL WARRANTIES, EXPRESS OR IMPLIED, INCLUDING, WITHOUT LIMITATION, ANY IMPLIED WARRANTIES OF MERCHANTABILITY, FITNESS FOR A PARTICULAR PURPOSE, OR NON-INFRINGEMENT OF THIRD-PARTY INTELLECTUAL PROPERTY RIGHTS.

These resources are intended for developers who are designing with Renesas products. You are solely responsible for (1) selecting the appropriate products for your application, (2) designing, validating, and testing your application, and (3) ensuring your application meets applicable standards, and any other safety, security, or other requirements. These resources are subject to change without notice. Renesas grants you permission to use these resources only to develop an application that uses Renesas products. Other reproduction or use of these resources is strictly prohibited. No license is granted to any other Renesas intellectual property or to any third-party intellectual property. Renesas disclaims responsibility for, and you will fully indemnify Renesas and its representatives against, any claims, damages, costs, losses, or liabilities arising from your use of these resources. Renesas' products are provided only subject to Renesas' Terms and Conditions of Sale or other applicable terms agreed to in writing. No use of any Renesas resources expands or otherwise alters any applicable warranties or warranty disclaimers for these products.

(Disclaimer Rev.1.01 Jan 2024)

### Corporate Headquarters

TOYOSU FORESIA, 3-2-24 Toyosu,  
Koto-ku, Tokyo 135-0061, Japan  
[www.renesas.com](http://www.renesas.com)

### Trademarks

Renesas and the Renesas logo are trademarks of Renesas Electronics Corporation. All trademarks and registered trademarks are the property of their respective owners.

### Contact Information

For further information on a product, technology, the most up-to-date version of a document, or your nearest sales office, please visit [www.renesas.com/contact-us/](http://www.renesas.com/contact-us/).