

# 36V 2ch Stepping Motor Driver

## BD63888MUV

### General Description

BD63888MUV is a bipolar low-consumption driver that driven by PWM constant current. Rated power supply voltage of the device is 36 V, and rated output current is 1.2 A. CLK-IN drive mode is adopted for input interface, and excitation mode is corresponding to FULL STEP mode, HALF STEP mode (2 types) and QUARTER STEP mode via a built-in DAC. The power supply can be driven by one single system, which simplifies the design.

### Features

- Two bipolar stepping motors can be driven
- Rated Output Current 1.2 A
- Low ON Resistance DMOS Output
- CLK-IN Drive Mode Correspondence
- PWM Constant Current Control (the other excitation method)
- Built-in Spike Noise Blanking Function (external noise filter is unnecessary)
- Full-, Half (two kinds)-, Quarter-step Functionality
- Free Timing Excitation Mode Switch
- Decay Mode Switch Function
- Normal Rotation and Reverse Rotation Switching Function
- Power Save Function
- Built-in Logic Input Pull-down Resistor
- Power-on Reset Function
- Thermal Shutdown Circuit (TSD)
- Over-current Protection Circuit (OCP)
- Under Voltage Lockout Circuit (UVLO)
- Over Voltage Lockout Circuit (OVLO)
- Ghost Supply Prevention (protects against malfunction when power supply is disconnected)

### Application

- Monitoring Camera, WEB Camera, PPC, Multi-function Printer, Laser Beam Printer, Ink-jet Printer, Sewing Machine, Photo Printer, FAX, Scanner, Mini Printer, Toy and Robot

### Key Specifications

- Range of Power Supply Voltage 8 V to 28 V
- Rated Output Current 1.2 A
- Range of Operating Temperature -25 °C to +85 °C
- Output ON Resistance 1.0 Ω (Typ)  
(total of upper and lower resistors)

### Package

VQFN036V6060

W(Typ) x D(Typ) x H(Max)  
6.0 mm x 6.0 mm x 1.0 mm

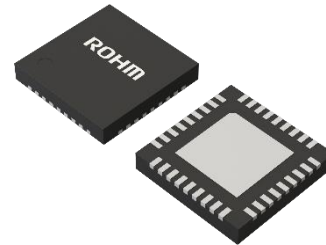

### Typical Application Circuit

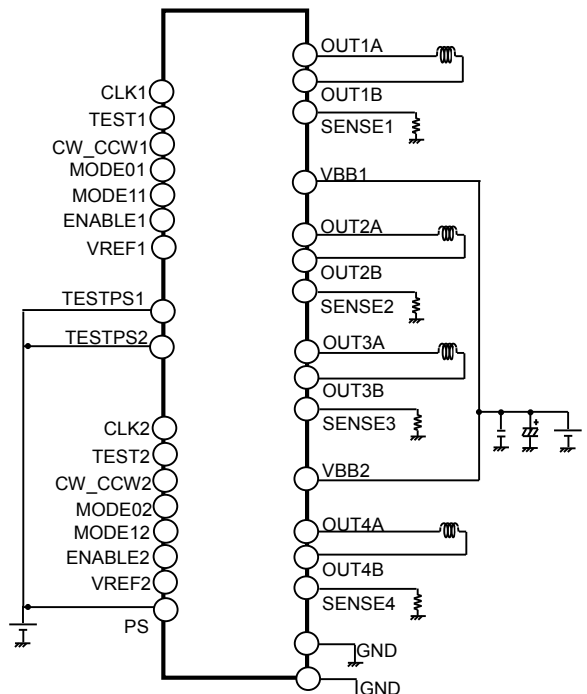

Figure 1. BD63888MUV Application Circuit Diagram

Pin Configuration

[TOP VIEW]

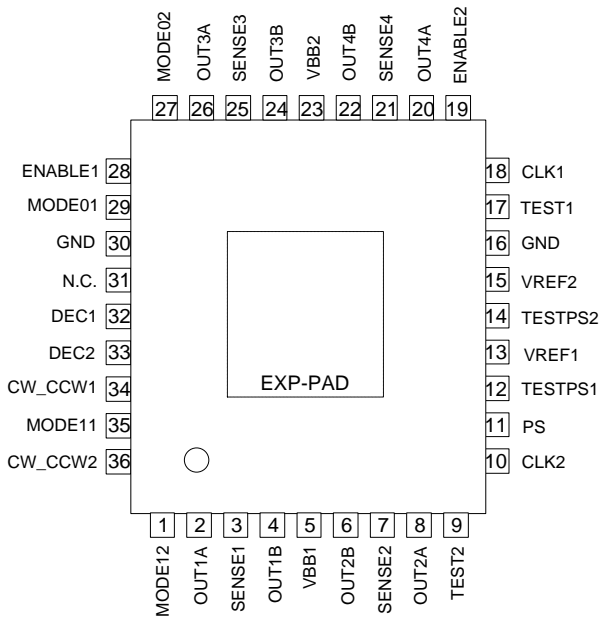

Figure 2. Pins Configuration Diagram

Block Diagram

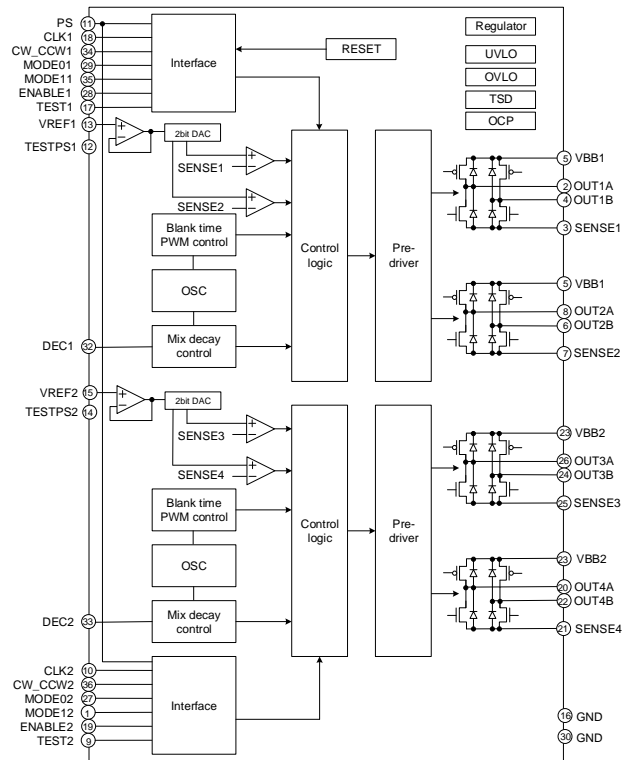

Figure 3. BD63888MUV Block Diagram

Pin Description

Pin No.	Pin Name	Function	Pin No.	Pin Name	Function
1	MODE12	2ch motor excitation mode setting pin	19	ENABLE2	2ch pin for enabling output
2	OUT1A	H bridge output pin	20	OUT4A	H bridge output pin
3	SENSE1	Connection pin of resistor for output current detection	21	SENSE4	Connection pin of resistor for output current detection
4	OUT1B	H bridge output pin	22	OUT4B	H bridge output pin
5	VBB1	Power supply pin	23	VBB2	Power supply pin
6	OUT2B	H bridge output pin	24	OUT3B	H bridge output pin
7	SENSE2	Connection pin of resistor for output current detection	25	SENSE3	Connection pin of resistor for output current detection
8	OUT2A	H bridge output pin	26	OUT3A	H bridge output pin
9	TEST2	Pin for testing (Use it connecting with GND)	27	MODE02	2ch motor excitation mode setting pin
10	CLK2	2ch advancement clock input pin	28	ENABLE1	1ch pin for enabling output
11	PS	Power save pin	29	MODE01	1ch motor excitation mode setting pin
12	TESTPS1	Pin for testing (Use it connecting with the PS pin)	30	GND	Ground pin
13	VREF1	Output current value setting pin	31	N.C.	No connection
14	TESTPS2	Pin for testing (Use it connecting with the PS pin)	32	DEC1	1ch current decay mode setting pin
15	VREF2	Output current value setting pin	33	DEC2	2ch current decay mode setting pin
16	GND	Ground pin	34	CW_CCW1	1ch motor rotating direction setting pin
17	TEST1	Pin for testing (Use it connecting with GND)	35	MODE11	1ch motor excitation mode setting pin
18	CLK1	1ch advancement clock input pin	36	CW_CCW2	2ch motor rotating direction setting pin
-	EXP-PAD	The EXP-PAD of the center of product connect to GND.	-	-	-

**Absolute Maximum Ratings (Ta=25 °C)**

Item	Symbol	Rated Value	Unit
Supply Voltage	VBB1, VBB2	-0.2 to +36.0	V
Input Voltage for Control Pin	V <sub>IN</sub>	-0.2 to +5.5	V
SENSE Maximum Voltage	V <sub>SENSE</sub>	0.7	V
Output Current	I <sub>OUT</sub>	1.2 <sup>(Note 1)</sup>	A/Phase
Storage Temperature Range	T <sub>stg</sub>	-55 to +150	°C
Maximum Junction Temperature	T <sub>jmax</sub>	+150	°C

**Caution 1:** Operating the IC over the absolute maximum ratings may damage the IC. The damage can either be a short circuit between pins or an open circuit between pins and the internal circuitry. Therefore, it is important to consider circuit protection measures, such as adding a fuse, in case the IC is operated over the absolute maximum ratings.

**Caution 2:** Should by any chance the maximum junction temperature rating be exceeded the rise in temperature of the chip may result in deterioration of the properties of the chip. In case of exceeding this absolute maximum rating, design a PCB boards with thermal resistance taken into consideration by increasing board size and copper area so as not to exceed the maximum junction temperature rating.

(Note 1) Do not exceed T<sub>jmax</sub>=150 °C.

**Recommended Operating Conditions**

Item	Symbol	Min	Typ	Max	Unit
Operating Temperature	Topr	-25	+25	+85	°C
Supply Voltage	VBB1, VBB2	+8	+24	+28	V
Maximum Output Current (DC)	I <sub>OUT</sub>	-	-	+1.0	A/Phase

(Note 2) Do not exceed T<sub>jmax</sub>=150 °C.

**Thermal Resistance<sup>(Note 3)</sup>**

Parameter	Symbol	Thermal Resistance (Typ)		Unit
		1s <sup>(Note 5)</sup>	2s2p <sup>(Note 6)</sup>	
VQFN036V6060				
Junction to Ambient	θ <sub>JA</sub>	103.9	24.5	°C/W
Junction to Top Characterization Parameter <sup>(Note 4)</sup>	Ψ <sub>JT</sub>	4	2	°C/W

(Note 3) Based on JESD51-2A (Still-Air).

(Note 4) The thermal characterization parameter to report the difference between junction temperature and the temperature at the top center of the outside surface of the component package.

(Note 5) Using a PCB board based on JESD51-3.

(Note 6) Using a PCB board based on JESD51-5, 7.

Layer Number of Measurement Board	Material	Board Size
Single	FR-4	114.3 mm x 76.2 mm x 1.57 mmt

Top	
Copper Pattern	Thickness
Footprints and Traces	70µm

Layer Number of Measurement Board	Material	Board Size	Thermal Via <sup>(Note 7)</sup>	
			Pitch	Diameter
4 Layers	FR-4	114.3 mm x 76.2 mm x 1.6 mmt	1.20 mm	Φ0.30 mm

Top		2 Internal Layers		Bottom	
Copper Pattern	Thickness	Copper Pattern	Thickness	Copper Pattern	Thickness
Footprints and Traces	70 µm	74.2 mm x 74.2 mm	35 µm	74.2 mm x 74.2 mm	70 µm

(Note 7) This thermal via connects with the copper pattern of all layers.

## Electrical Characteristics (Unless otherwise specified Ta=25 °C, VBB1, VBB2=24 V)

Item	Symbol	Limit			Unit	Condition
		Min	Typ	Max		
<b>[Whole]</b>						
Circuit Current at Standby	I <sub>CCST</sub>	-	0	10	μA	PS=L
Circuit Current	I <sub>CC</sub>	-	5.0	8.0	mA	PS=H, VREF <sub>x</sub> (Note 8)=1.5 V
<b>[Control Input]</b>						
H-level Input Voltage	V <sub>INH1</sub>	2.0	-	-	V	
L-level Input Voltage	V <sub>INL1</sub>	-	-	0.8	V	
H-level Input Current	I <sub>INH1</sub>	35	50	100	μA	V <sub>IN</sub> =5 V
L-level Input Current	I <sub>INL1</sub>	-10	0	-	μA	V <sub>IN</sub> =0 V
<b>[Control Input] (TESTPS1, TESTPS2)</b>						
H-level Input Voltage	V <sub>INH</sub>	2.8	-	-	V	
L-level Input Voltage	I <sub>INH</sub>	-	0	10	μA	V <sub>IN</sub> =5 V
L-level Input Current	I <sub>INL</sub>	-2.0	-0.1	-	μA	V <sub>IN</sub> =0 V
<b>[Output]</b>						
Output ON Resistance	R <sub>ON</sub>	-	1.0	1.4	Ω	I <sub>OUT</sub> =±1.0 A (total of upper and lower resistors)
Output Leak Current	I <sub>LEAK</sub>	-	-	10	μA	
<b>[Current Control]</b>						
SENSE <sub>x</sub> (Note 9) Input Current	I <sub>SENSE</sub>	-80	-40	-	μA	SENSE <sub>x</sub> =0 V
VREF <sub>x</sub> Input Current	I <sub>VREF</sub>	-2.0	-0.1	-	μA	VREF <sub>x</sub> =0 V
VREF <sub>x</sub> Input Voltage Range	V <sub>VREF</sub>	0	-	1.5	V	
Minimum ON Time (Blank Time)	t <sub>ONMIN</sub>	0.3	1.0	1.5	μs	
Comparator Threshold	V <sub>CTH</sub>	0.48	0.50	0.52	V	VREF <sub>x</sub> =1.5 V

(Note 8) x=1 or 2

(Note 9) x=1,2,3 or 4

**Function Explanation**

CLKx<sup>(Note 10)</sup>/Clock input Pin for advancing the electrical angle

CLKx is working on rising edge. The Electrical angle advances by one for each CLK input.  
 Motor's misstep will occur if noise gets mixed with the CLKx pin, so design the pattern there is no noise plunging.  
 (Note 10) x=1 or 2

MODE0x<sup>(Note 11)</sup>, MODE1x<sup>(Note 12)</sup>/Motor Excitation Mode Setting Pin

Set the motor excitation mode

MODE0x	MODE1x	Excitation Mode
L	L	FULL STEP
H	L	HALF STEP A
L	H	HALF STEP B
H	H	QUARTER STEP

(Note 11) x=1 or 2  
 (Note 12) x=1 or 2

Refer to the P.12, 13 for the timing chart and motor torque vector of various excitation modes.  
 Unrelated to CLK, change of setting is forcibly reflected. (refer to P.15).

CW\_CCWx<sup>(Note 13)</sup>/Motor Rotating Direction Setting Pin

Set the motor's rotating direction. Change of setting is reflected by the CLK rising edge immediately after that. (refer to P.14)

CW_CCWx	Rotating Direction
L	Clockwise (CH2's current is outputted with a phase lag of 90° on the basis of CH1's current)
H	Counter Clockwise (CH2's current is outputted with a phase lead of 90° on the basis of CH1's current)

(Note 13) x=1 or 2

ENABLEx<sup>(Note 14)</sup>/Output Enable Pin

Turn off forcibly all the output transistors (motor output is open).  
 When ENABLE=L, input to CLK is blocked, and phase advance operation of internal translator circuit is stopped.  
 However, when the excitation mode (MODE 0X, MODE 1X) is switched in the ENABLE=L period, the switched mode is valid as the excitation mode when the ENABLE Pin returns from Low to High. (refer to P.15)

ENABLEx	Motor Output
L	OPEN (electrical angle maintained)
H	ACTIVE

(Note 14) x=1 or 2

PS /Power Save Pin

The PS pin can make circuit standby state and motor output OPEN. In standby state, translator circuit is reset (initialized) and electrical angle is initialized.  
 Be careful because there is a delay of 40 μs (Max), as PS=L→H, until it is returned from standby state to normal state and the motor output becomes ACTIVE (refer to P.11).

PS	Status
L	Standby State(RESET)
H	ACTIVE

The electrical angle (initial electrical angle) of each excitation mode immediately after RESET is as follows.  
 (refer to P.12, 13)

Excitation Mode	Initial Electrical Angle
FULL STEP	45°
HALFSTEP A	45°
HALFSTEP B	45°
QUARTER STEP	45°

DECx<sup>(Note 15)</sup>/Current Decay Mode-setting Pin

This is the Pin to set the current decay mode.

DECx	Decay mode
L	SLOW DECAY
H	MIX DECAY

(Note 15) x=1 or 2

## Function Explanation – continued

### VBB1, VBB2/Power Supply Pin

The wire is thick, short and has low impedance, because Motor's drive current is flowing in it. The VBB1 pin and the VBB2 pin voltage may have great fluctuation, so arrange the bypass capacitor of about 100 μF to 470 μF as close to the pin as possible and adjust the VBB1 pin and the VBB2 pin voltage are stable. Increase the capacity as needed especially, when a large current is used or those motors that have great back electromotive force are used.

In addition, for the purpose of reducing of power supply's impedance in wideband, it is recommended to set parallel connection of multi-layered ceramic capacitor of 0.01 μF to 0.1 μF etc. Extreme care must be used to make sure that the VBB1 pin and the VBB2 pin voltage does not exceed the rating even for a moment. The VBB1 pin and the VBB2 pin are shorted inside the IC, but be sure to short externally the VBB1 pin and the VBB2 pin when using. If used without shorting, malfunction or destruction may occur because of concentration of current routes etc. Still more, in the power supply pin, there is built-in clamp component for preventing of electrostatic destruction. When a steep pulse signal or voltage such as a surge exceeding the absolute maximum rating is applied, this clamp component operates, and the IC might be destroyed as a result. Be sure that the maximum absolute rating must not be exceeded. It is effective to mount a Zener diode of about the maximum absolute rating. Moreover, the diode for preventing electrostatic destruction is inserted between the VBB1 pin, the VBB2 pin and the GND pin. Be careful about the reverse voltage because the IC might be destroyed as a result if reverse voltage is applied to the VBB1 pin, the VBB2 pin and the GND pin

### GND/Ground Pin

In order to reduce the electric noise by switching current and to stabilize the internal reference voltage of the IC, make the wiring impedance from this pin as low as possible to achieve the lowest electrical potential no matter what operating state it can be. Moreover, design the patterns not to have any common impedance with other GND patterns.

### OUTxA<sup>(Note 16)</sup>, OUTxB<sup>(Note 17)</sup>/H Bridge Output Pin

Motor's drive current is flowing in it, so the wire is thick, short and has low impedance. It is also effective to add a Schottky diode if output has positive or negative great fluctuation when large current is used. For example, counter electromotive voltage etc. Moreover, in the output Pin, there is built-in clamp component for preventing of electrostatic destruction. When a steep pulse signal or voltage such as a surge exceeding the absolute maximum rating is applied, this clamp component operates, and the IC might be destroyed in the end. Be be sure that the maximum absolute rating must not exceeded.

(Note 16) x=1, 2, 3 or 4

(Note 17) x=1, 2, 3 or 4

### SENSEx<sup>(Note 18)</sup>/Connection Pin of Resistor for Detecting of Output Current

Connect the resistor of 0.1Ω to 0.3Ω for current detection between this pin and GND. Determine the resistor so that power consumption  $W=I_{OUT}^2 \cdot R$  [W] of the current-detecting resistor does not exceed the maximum absolute rating of the resistor. In addition, it has a low impedance and does not have a common impedance with other GND patterns because motor's drive current flows in the pattern through the SENSEx pin to current-detecting resistor to GND. Do not exceed the rating because there is the possibility of circuits' malfunction etc., if the SENSE pin voltage exceeds the maximum rating (0.7 V). Moreover, be careful because if the SENSEx pin is shorted to GND, large current flows without normal PWM constant current control, and OCP or TSD might operate. If there is a possibility of malfunction, such as output does not flow even when the SENSEx pin is open, please do not to such a state.

(Note 18) x=1, 2, 3 or 4

### VREFx<sup>(Note 19)</sup>/Output Current Value Setting Pin

This is the pin to set the output current value. It can be set by the VREF pin voltage and current-detecting resistor (SENSE resistor).

(Note 19) x=1 or 2

$$I_{OUT} = \frac{V_{REF}}{3} / SENSE \quad [A]$$

Where:

$I_{OUT}$  is the output current.

$V_{REF}$  is the voltage of output current value-setting pin.

$SENSE$  is the current-detecting resistor.

Avoid using the IC with the VREFx pin is open because if it is open, it may have malfunctions such as flowing a large current by unstable input, the increased the VREFx pin voltage and increased setting current. The input voltage range must be kept because a large current might flow to output and OCP or TSD might operate if the voltage of over 1.5 V is applied on the VREFx pin. Besides, select the resistance value in consideration of the outflow current (Max 2 μA) if it is inputted by resistance division. The minimum current, which can be controlled by the VREFx pin voltage, is determined by motor coil's L, R values and minimum ON time because there is a minimum ON time in PWM drive.

**Function Explanation – continued**TESTx<sup>(Note 20)</sup>/Pin for Inspection

This pin is used for delivery inspection of the IC, and shall be connected to GND before use.  
In addition, malfunctions can be caused by application without grounding.

(Note 20) x=1 or 2

TESTPSx<sup>(Note 21)</sup> Pin/Pin for Inspection

This pin is used for delivery inspection of the IC, and shall be connected to power supplies less than 5.5 V before use.  
In addition, malfunctions can be caused by application without pull-up.

(Note 21) x=1 or 2

NC Pin

This pin is unconnected electrically with the IC internal circuit.

EXP-PAD

For VQFN036V6060 package, the heat-radiating metal is mounted on the IC's backside. It is the precondition that making the heat-radiating treatment when in use. Therefore, it must be connected by solder with the GND plane on the board and ensure the sufficient heat-radiation area by taking the GND pattern as wide as possible. Moreover, the backside metal is shorted with IC chip's backside and becomes the GND potential, so there is the danger of malfunction and destruction if shorted with potentials other than GND. Never design any wiring patterns other than GND through the IC's backside.

## Protection Circuits

### Thermal Shutdown (TSD)

This IC has a built-in thermal shutdown circuit for thermal protection. When the IC's chip temperature rises to 175 °C (Typ) or more, the motor output becomes OPEN. Also, when the temperature returns to 150 °C (Typ) or less, it automatically returns to normal operation. However, if heat is continued to be added externally even while TSD is in operation, heat overdrive can lead to destruction.

### Over Current Protection (OCP)

This IC has a built in over current protection circuit as a provision against destruction when the motor outputs are shorted each other or VBB1, VBB2-motor output or motor output-GND is shorted. This circuit latches the motor output to OPEN condition when the regulated current flows for 4 μs (Typ). It returns with power reactivation by a reset of the PS pin. The over current protection circuit's only aim is to prevent the destruction of the IC from irregular situations such as motor output shorts, and is not meant to be used as protection or security for the set. Therefore, sets should not be designed to take into account this circuit's functions. After OCP operating, if irregular situations continue and the return by power reactivation or a reset of the PS pin is carried out repeatedly, then OCP operates repeatedly and the IC may generate heat or otherwise deteriorate. When the L value of the wiring is great due to the wiring being long of faults, ground faults and shorting, there is a possibility of destruction after the over current has flowed and the output pin voltage jumps up and the absolute maximum values can be exceeded. Also, when current which is the output current rating or more and the OCP detection current or less flows, the IC can heat up to over  $T_{jmax}=150$  °C and can deteriorate, so current which exceeds the output rating should not be applied.

### Under Voltage Lockout (UVLO)

This IC has a built-in under voltage lockout function to prevent false operation such as IC output during power supply under voltage. When the applied voltage to the VBB1 pin and the VBB2 pin goes 5 V (Typ) or less, the motor output is set to OPEN. This switching voltage has a 1 V (Typ) hysteresis to prevent malfunction such as noise etc. Be aware that this circuit does not operate during power save mode. Also, the electrical angle is reset when the UVLO circuit operates.

### Over Voltage Lockout (OVLO)

This IC has a built-in over voltage lockout function to protect the IC output and the motor during power supply over voltage. When the applied voltage to the VBB1 pin and the VBB2 pin goes 32 V (Typ) or more, the motor output is set to OPEN. This switching voltage has a 1 V (Typ) hysteresis and a 4 μs (Typ) mask time to prevent malfunction such as noise etc. Although this over voltage locked out circuit is built-in, there is a possibility of destruction if the absolute maximum value for power supply voltage is exceeded, therefore the absolute maximum value should not be exceeded. Be aware that this circuit does not operate during power save mode.

### Ghost Supply Prevention (protects against malfunction when power supply is disconnected)

If a control signal (logic input,  $VREF_x$ <sup>(Note 22)</sup>) is input when there is no power supplied to this IC, there is a function which prevents a malfunction where voltage is supplied to power supply of this IC or other IC in the set via the electrostatic destruction prevention diode from these input pins to the VBB1 pin and VBB2 pin. Therefore, there is no malfunction of the circuit even when voltage is supplied to these input pins while there is no power supply.

(Note 22) x=1 or 2

### Operation Under Strong Electromagnetic Field

The IC is not designed for using in the presence of strong electromagnetic field. Be sure to confirm that no malfunction is found when using the IC in a strong electromagnetic field.

**PWM Constant Current Control**

1) Current control operation

The output current increases due to the output transistor turned on. When the voltage on the SENSE<sub>x</sub><sup>(Note 23)</sup> pin, the output current is converted voltage due to connect the external resistance to the SENSE<sub>x</sub> pin, reaches the voltage value set by the internal 2-bit DAC and the VREF<sub>x</sub><sup>(Note 24)</sup> input voltage, the current limit comparator engages and enters current decay mode. Thereafter the output turned on again after a period of time determined the internal timer. The process repeats itself constantly.

(Note 23) x=1, 2, 3 or 4

(Note 24) x=1 or 2

2) Noise-masking function

In order to avoid misdetection of current detection comparator due to SENSE<sub>x</sub> spikes noise that may occur when the output turns on, the IC employs the minimum ON-time ( $t_{ONMIN}$ ). It invalids the current detection for the minimum ON-time of 1  $\mu$ s (Typ) from the output transistor turned on. This allows constant-current drive without the need for an external filter.

3) Internal Timer

IC internal voltage repeat charging and discharging between VL to VH.

The detection of the internal comparator is masked while charging from VL to VH in order to cancel noise. This period defines the minimum ON-time ( $t_{ONMIN}$ ) of the motor output transistor. The internal voltage begins discharging once the voltage reaches VH. When the output current reaches the current limit during this period, then the IC enters decay mode. It reaches VL, at which point the IC internal voltage is switched back ON. The current output and internal terminal begin charging simultaneously.

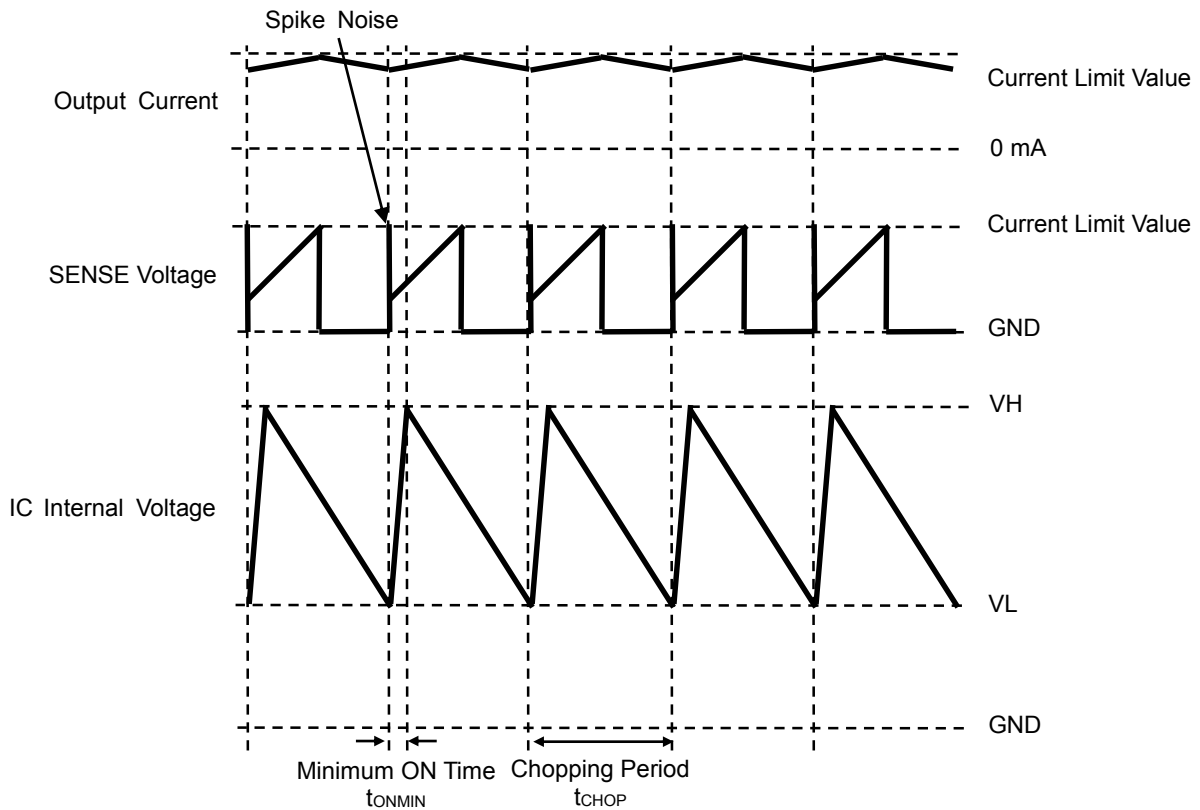

Figure 4. Timing Chart of IC Internal Voltage, the SENSE pin voltage and Output Current

**PWM Constant Current Control – continued**

**Current Decay Mode**

PWM Constant Current Control can be optionally set the current decay mode in which the ratio of MIX DECAY and SLOW DECAY.

The following diagrams show the state of each transistor and the regenerative current path during the current decay for each decay mode:

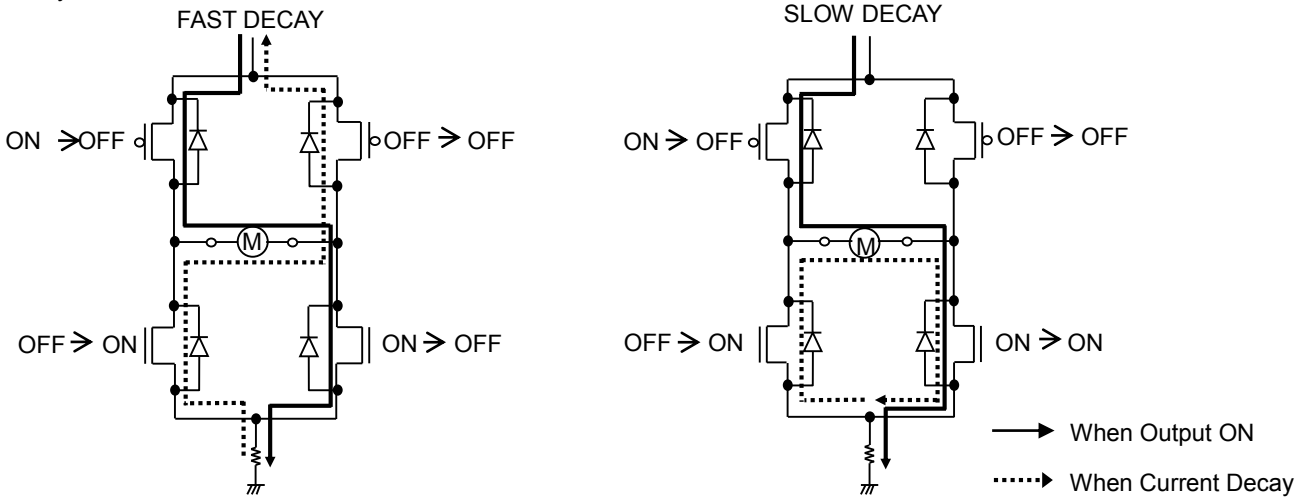

Figure 5. Route of Regenerated Current during Current Decay

The merits of each decay mode are as follows:

**SLOW DECAY**

The voltage of motor coils is small and the regenerative current decreases slowly. So the output current ripple is small and this is favorable for motor torque. However, output vibration increase without following the change in the current limit value according to increase in output current due to deterioration of current controllability in the low-current region and it is easily influenced by EMF when high-pulse-rate in HALF STEP or QUARTER STEP modes. Thus, this decay mode is most suited to FULL STEP modes or low-pulse-rate as HALF STEP or QUARTER STEP modes.

**FAST DECAY**

FAST DECAY decreases the regeneration current much more quickly than slow decay, greatly reducing distortion of the output current waveform. However, FAST DECAY yields a much larger output current ripple, which decreases the overall average current running through the motor. This causes two problems: first, the motor torque decreases (increasing the current limit value can help eliminate this problem, but the rated output current must be taken into consideration); and second, the power loss within the motor increases and thereby radiates more heat. If neither of these problems is of concern, then FAST DECAY can be used for high-pulse-rate HALF STEP or QUARTER STEP drive.

Additionally, this IC has MIX DECAY as a method to remedy the problems caused by the above SLOW DECAY and FAST DECAY. In this IC, SLOW DECAY / MIX DECAY (60 % Typ SLOW DECAY) can be selected.

Switching between SLOW DECAY and FAST DECAY during current decay can improve current control without increasing current ripple.

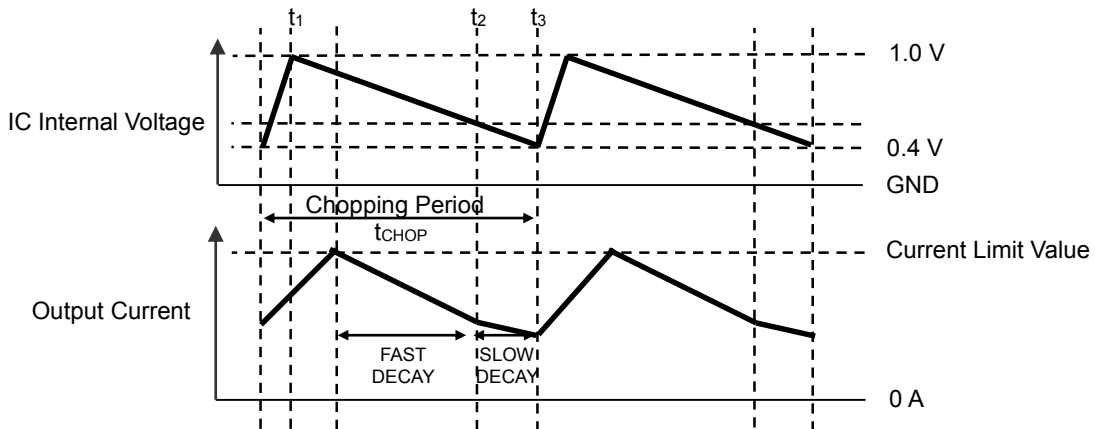

Figure 6. Internal Voltage and Output Current during MIX DECAY

**About translator circuit operation in CLK-IN drive system - Description for CH1 (CH2: same as CH1)-**

This series builds in translator circuit and can drive stepping motor in CLK-IN drive mode.  
The operation of the translator circuit in CLK-IN drive mode is described as below.

Reset Operation

The translator circuit is initialized by power ON reset function and the PS pin.

Initializing operation when power supply is turned on

(1) If power supply is turned on at PS=L (Use this sequence as a general rule)

When power supply is turned on, the power ON reset function operates in the IC and initialized, but as long as it is PS=L, the motor output is the OPEN state. After power supply is turned on, because of the changing of PS=L→H, the motor output becomes the ACTIVE state, and the excitation is started at the initial electrical angle.

But at the time of PS=L→H, it returns from the standby state to the normal state and there is a delay of 40 μs (Max) until the motor output has become the ACTIVE state.

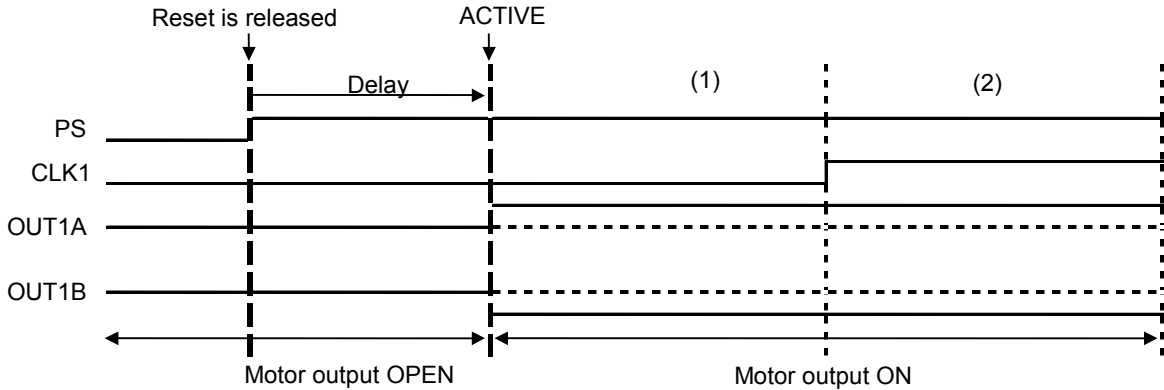

(2) If power supply is turned on at PS=H

When power supply is turned on, the power ON reset function operates in the IC and be initialized before the motor output becomes the ACTIVE state during ENABLE1=H, and the excitation is started at the initial electrical angle.

Initializing operation during motor operating

Input the reset signal to the PS pin when the translator circuit is initialized during motor fundamentally operating. (Refer to P.14) But at the time of PS=L→H, it returns from the standby state to the normal state and there is a delay of 40 μs (Max) until the motor output has become the ACTIVE state, so be careful.

Control Input Timing

Please observe the following input timing because basically the translator circuit operates at the rising edge of CLK signal. If you disobey this timing and input, then there is the possibility that the translator circuit does not operate as expected. In addition, at the time of PS=L→H, it returns from the standby state to the normal state and there is a delay of 40 μs (Max) until the motor output has become the ACTIVE state. Be careful that the phase advance operation does not work even if CLK is input within this delay interval.

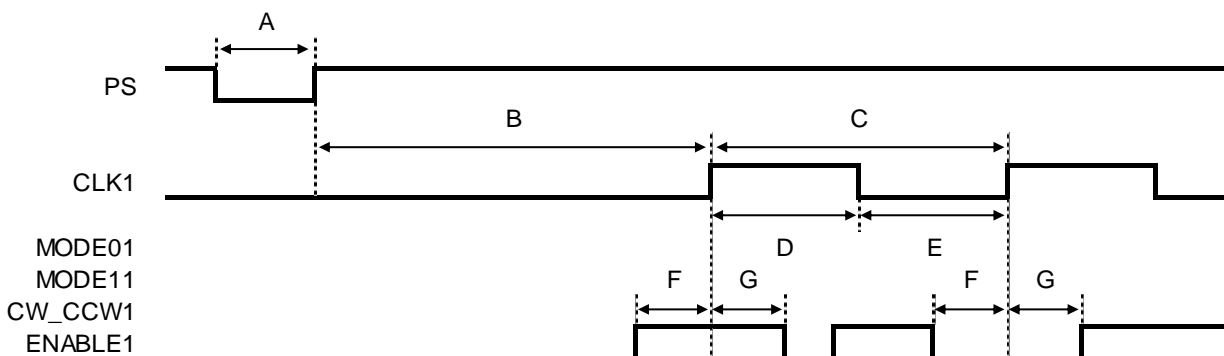

- A: PS minimum input L pulse width •••• 20 μs
- B: PS rising edge to CLK rising edge input possible maximum delay time •••• 40 μs
- C: CLK1 minimum period •••• 4 μs
- D: CLK1 minimum input H pulse width •••• 2 μs
- E: CLK1 minimum input L pulse width •••• 2 μs
- F: MODE01, MODE11, CW\_CCW1, ENABLE1 set-up time •••• 1 μs
- G: MODE01, MODE11, CW\_CCW1, ENABLE1 hold time •••• 1 μs

About translator circuit operation in CLK-IN drive system – continued

FULL STEP (MODE01=L, MODE11=L, CW CCW1=L, ENABLE1=H)

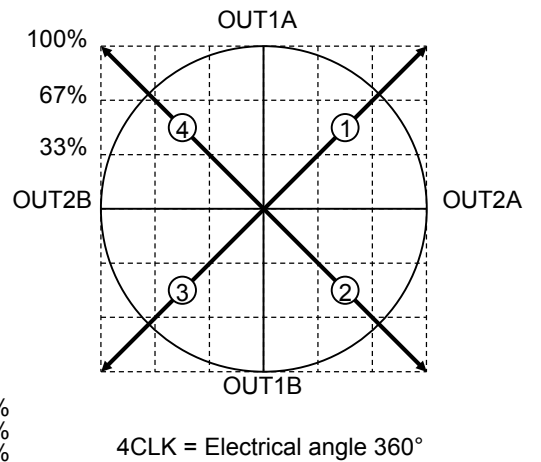
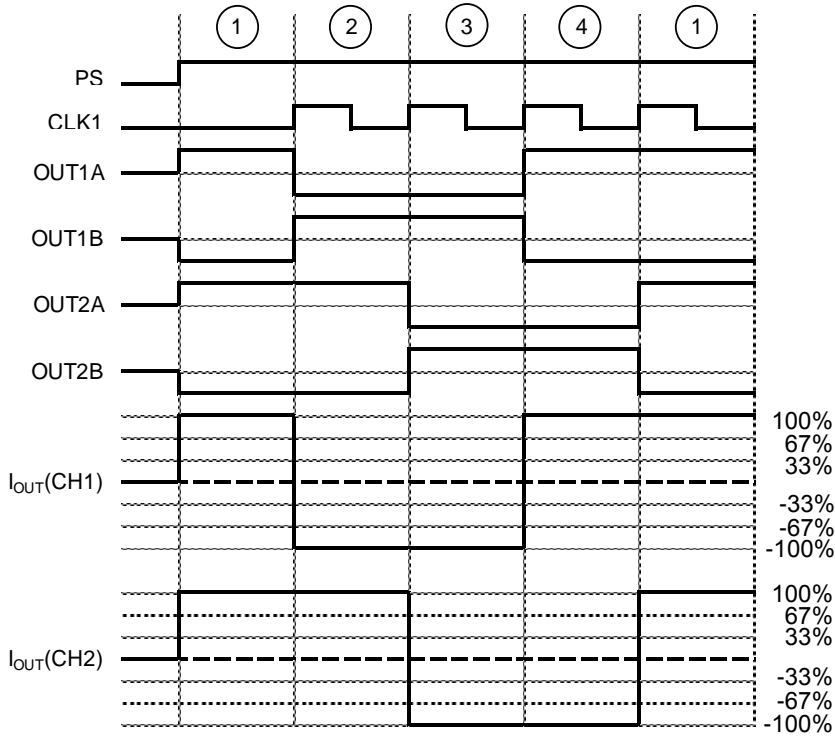

HALF STEP A (MODE01=H, MODE11=L, CW CCW1=L, ENABLE1=H)

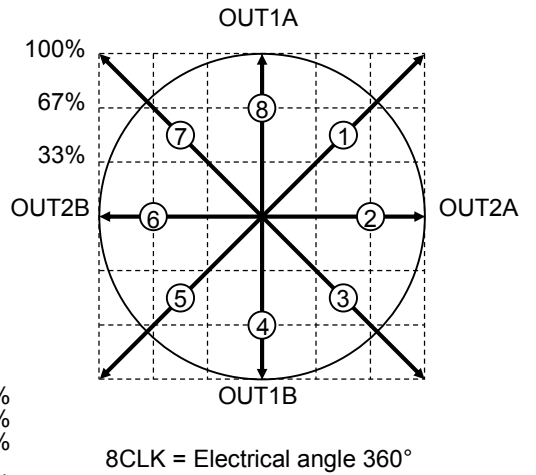
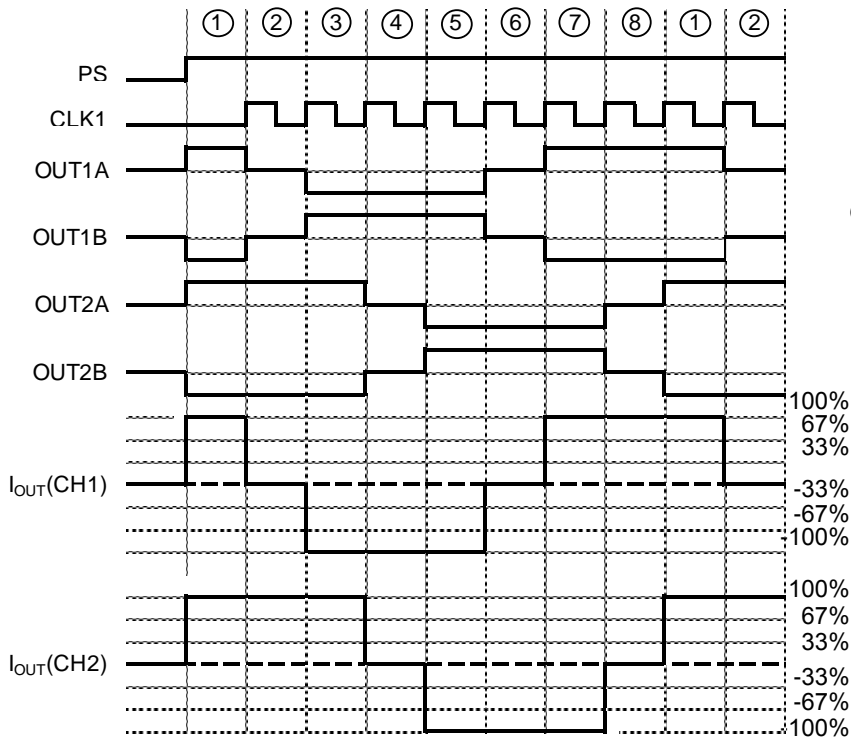

About translator circuit operation in CLK-IN drive system – continued

HALF STEP B (MODE01=L, MODE11=H, CW, CCW1=L, ENABLE1=H)

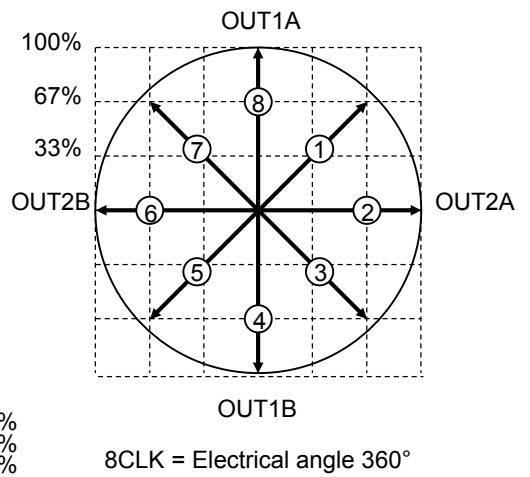
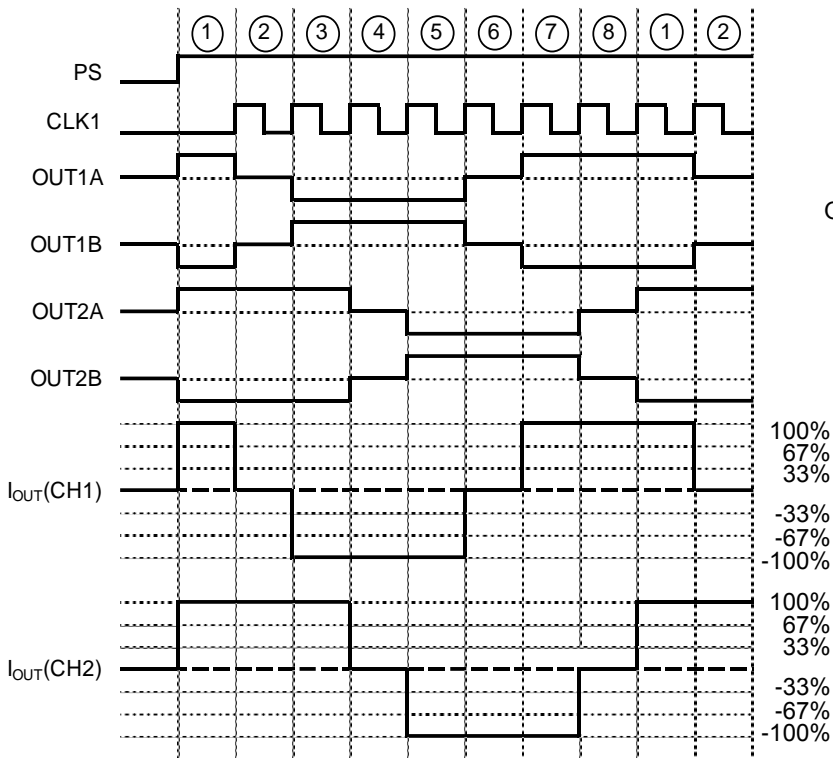

QUARTER STEP (MODE01=H, MODE11=H, CW, CCW1=L, ENABLE1=H)

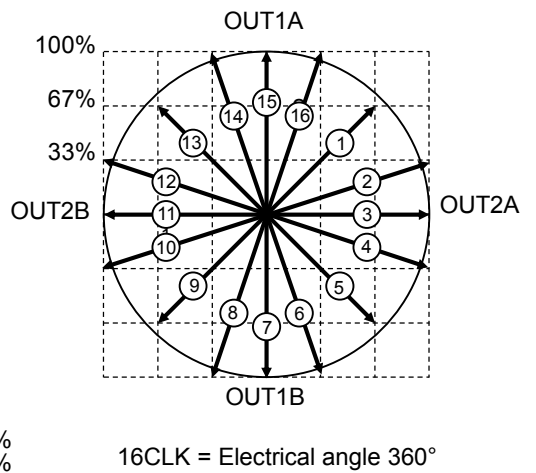
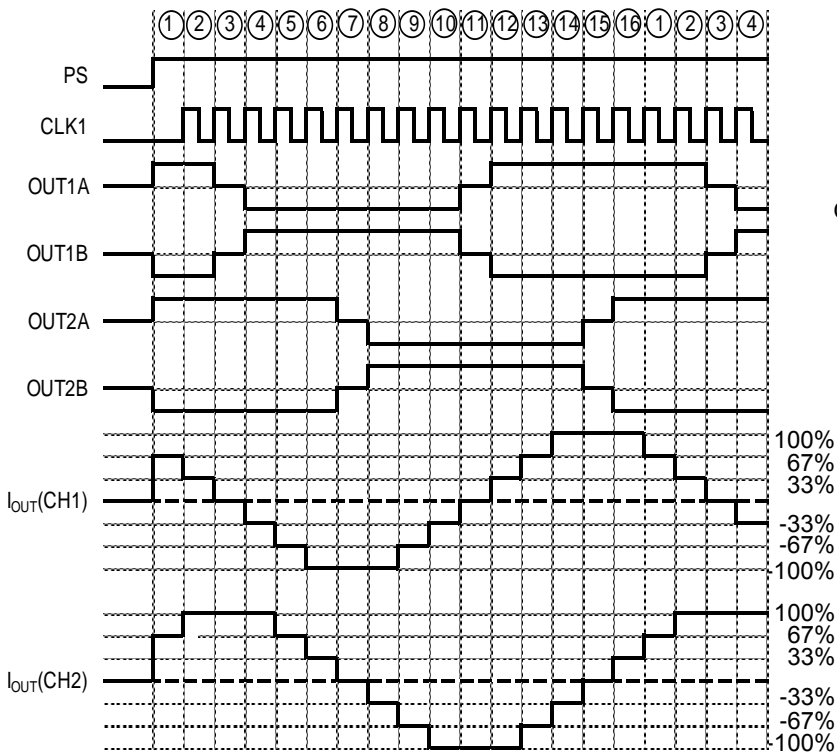

About translator circuit operation in CLK-IN drive system – continued

Reset Timing Chart (QUARTER STEP, MODE01=H, MODE11=H, CW CCW1=L, ENABLE1=H)

To reset the translator circuit while the motor is working, input the PS pin to L. The reset operation works regardless of other input signals. At this time, the IC internal circuit turns to the standby mode and makes the motor output OPEN.

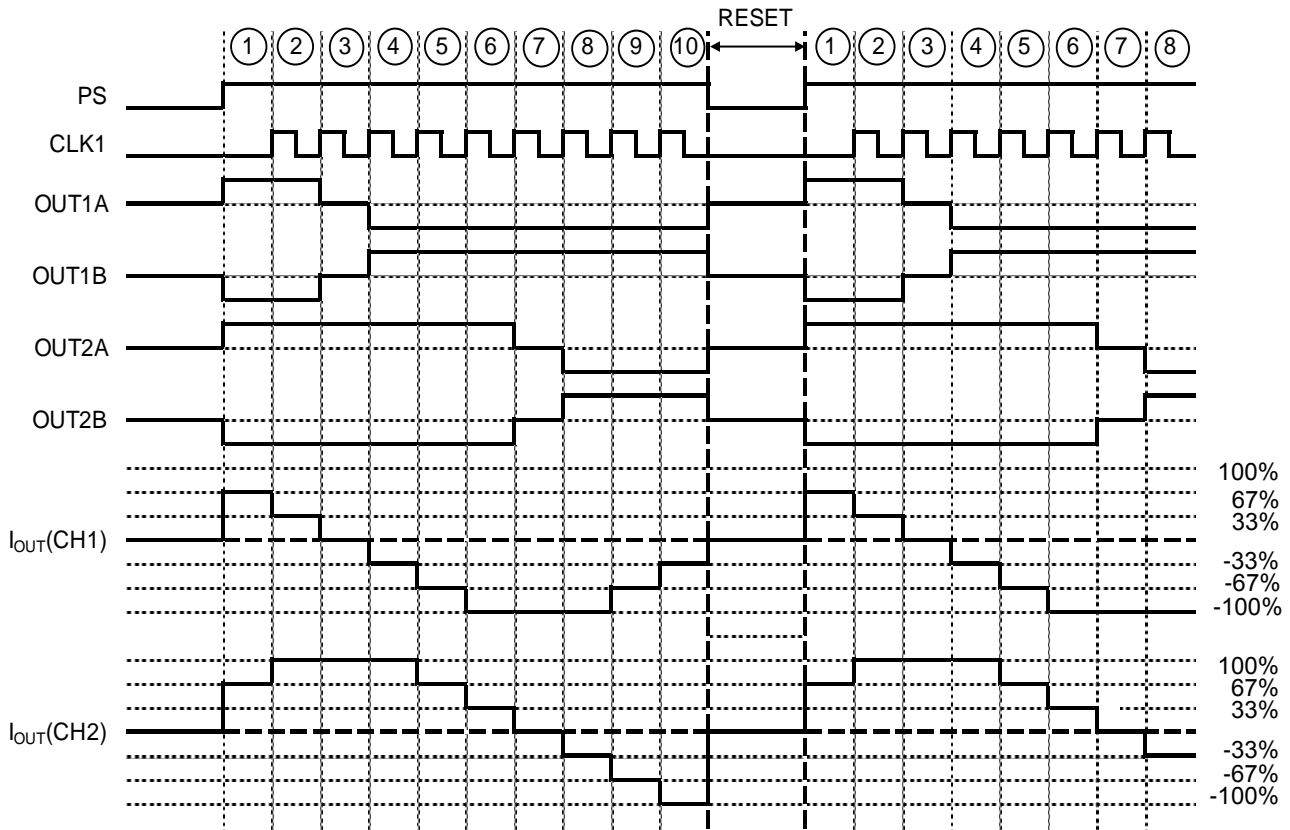

CW\_CCW Switch Timing Chart (FULL STEP, MODE01=L, MODE11=L, ENABLE1=H)

The switch of CW\_CCW is reflected by the rising edge of CLK1 that comes immediately after the changes of the CW\_CCW 1 signal. However, even if the control on driver IC side supports, the motor cannot follow and might make a step-out or a misstep depending on the state of operation of the motor at the switching. Evaluate the switching sequence sufficiently.

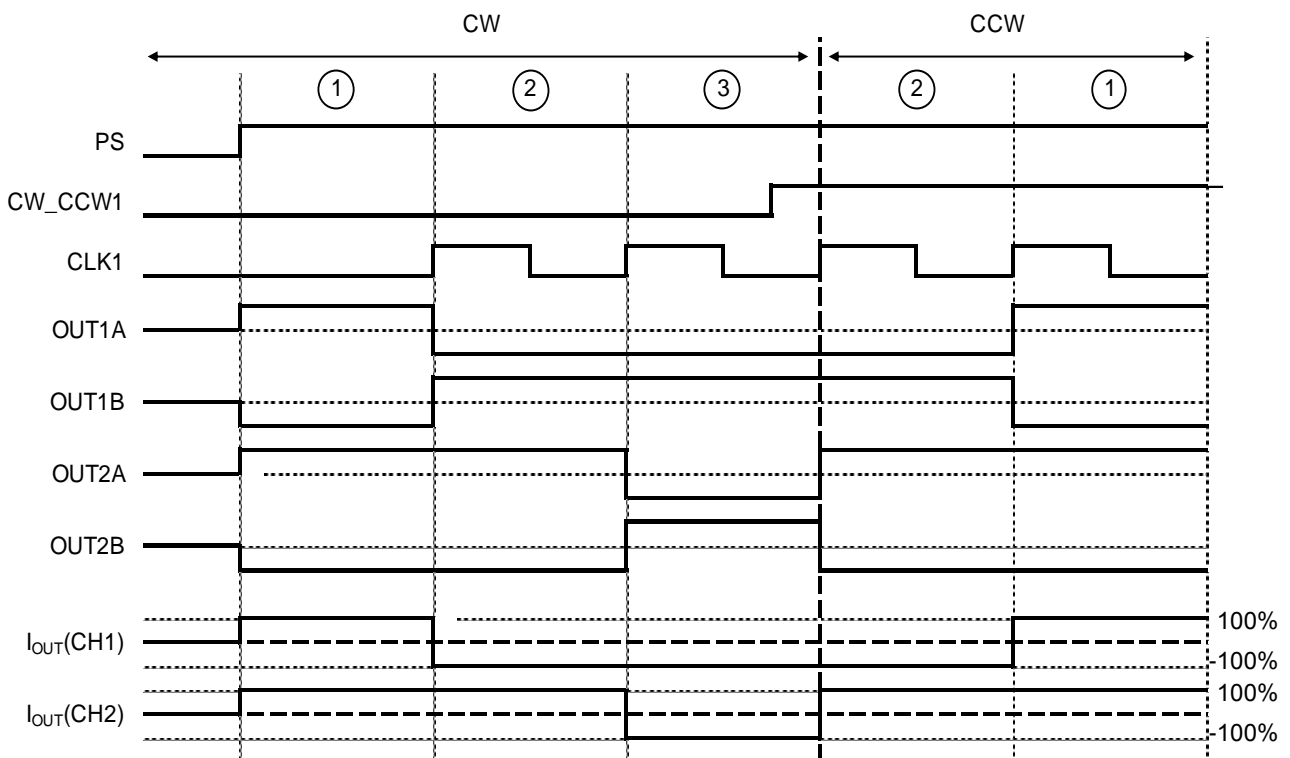

**About translator circuit operation in CLK-IN drive system – continued**

ENABLE Switch Timing Chart (FULL STEP, MODE01=L, MODE11=L)

The switch of the ENABLE signal is reflected by the change in the ENABLE signal with regardless of other input signals. In the section of ENABLE1=L, because the motor output becomes OPEN and the CLK input is cut off, the phase advance operation of the internal translator circuit stops. Therefore, the progress of ENABLE1=L to H is completed before the input of ENABLE1=L. Switching of the excitation mode (MODE01, MODE11) is performed even in the ENABLE1=L section. If excitation mode is switched in ENABLE1=L interval, it returns ENABLE1=L to H with the excitation mode which is after switched.

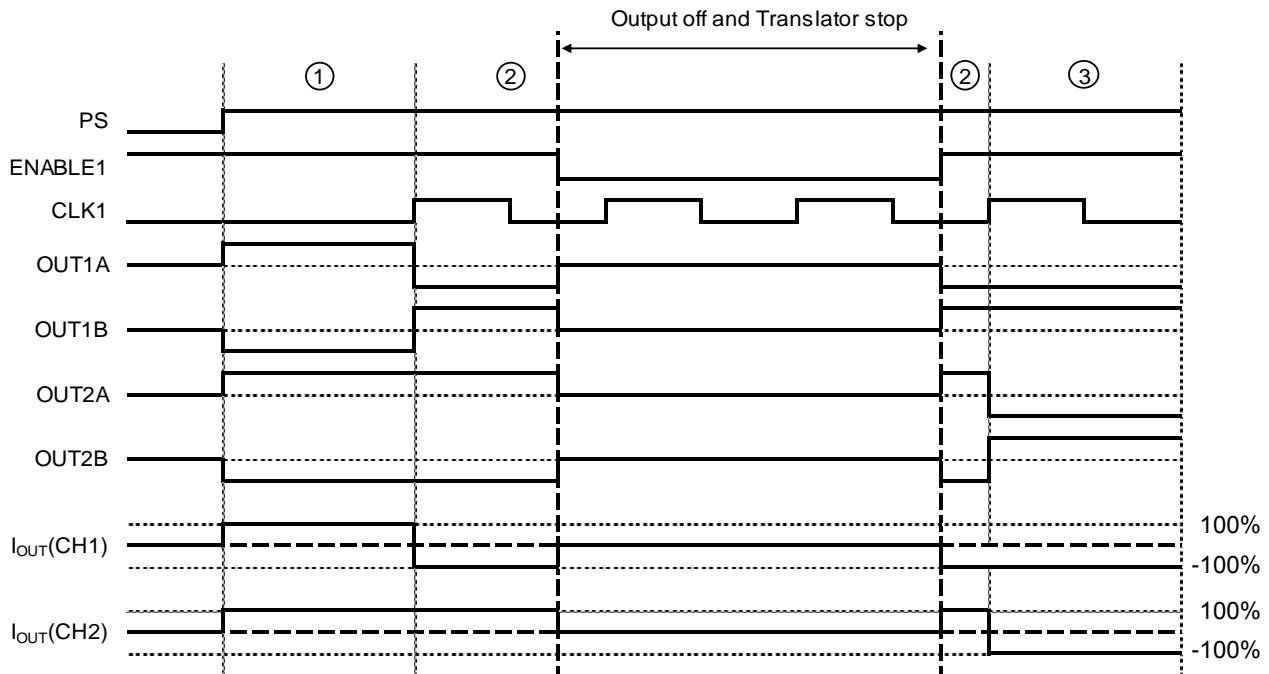

Returning in the state prior to input of ENABLE1=L

About the Switch of the Motor Excitation Mode

The switch of the excitation mode be done at the same time as changing of the signal MODE01 and MODE11 regardless of the CLK signal. This product has a function which prevents the motor step-out caused by discrepancies of torque vector of transitional excitations while excitation mode switching. However, even if the control on driver IC side supports, the motor cannot follow and might make a step-out or a misstep depending on the state of operation of the motor at the switching. Evaluate the switching sequence sufficiently.

Cautions of Bidirectional Switch of CW\_CCW1 and Excitation Modes (MODE01, MODE11)

As shown in the figure below, the area between the end of reset discharge (PS=L→H) and beginning of the first CLK signal input is defined as interval A, while the area from the end of the first CLK signal input is defined as interval B.

Interval A

=> For CW\_CCW1, no limitation is applied on switch of excitation mode.

Interval B

=> In CLK 1 period, or in ENABLE1=L interval, CW\_CCW1 and excitation mode cannot be switched together.

Violation of this restriction may lead to misstep (with one extra leading phase) or step-out.

Therefore, in case that CW\_CCW1 and excitation modes are switched simultaneously, the PS pin must be input reset signal. Then start to operate in interval A before carrying out such bidirectional switch.

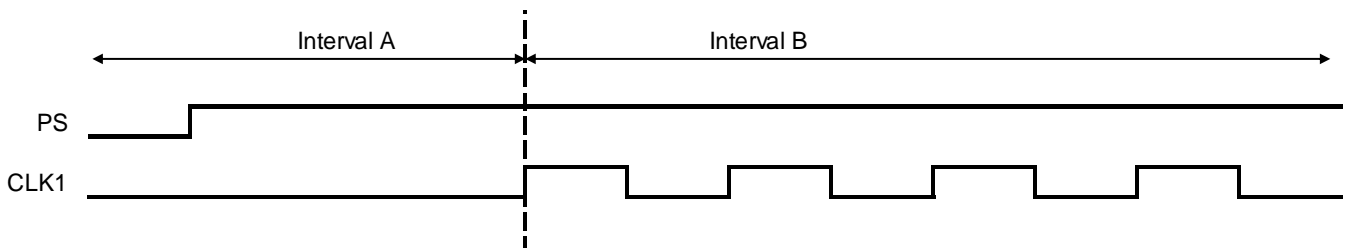

**Power Dissipation**

Confirm that the IC's chip temperature  $T_j$  is not over 150 °C in consideration of the IC's power consumption (W), thermal resistance (°C/W) and ambient temperature ( $T_a$ ). When  $T_j=150$  °C is exceeded, the functions as a semiconductor do not operate and problems such as parasitism and leaks occur. Constant use under these circumstances leads to deterioration and eventually destruction of the IC.  $T_{jmax}=150$  °C must be strictly obeyed under all circumstances.

Thermal Calculation

The IC's consumed power can be estimated roughly with the power supply voltage ( $V_{BB}$ ), circuit current ( $I_{CC}$ ), output ON resistance ( $R_{ONH}$ ,  $R_{ONL}$ ) and motor output current value ( $I_{OUT}$ ).

The calculation method during FULL STEP drive, SLOW DECAY mode is shown here:

$$W_{VBB} = V_{BB} \times I_{CC} \quad [W]$$

where:

- $W_{VBB}$  is the consumed power of the VBB.
- $V_{BB}$  is the power supply voltage.
- $I_{CC}$  is the circuit current.

$$W_{DMOS} = W_{ON} + W_{DECAY} \quad [W]$$

$$W_{ON} = (R_{ONH} + R_{ONL}) \times I_{OUT}^2 \times 2 \times on\_duty \quad [W]$$

$$W_{DECAY} = (2 \times R_{ONL}) \times I_{OUT}^2 \times 2 \times (1 - on\_duty) \quad [W]$$

where:

- $W_{DMOS}$  is the consumed power of the output DMOS.
- $W_{ON}$  is the consumed power during output ON.
- $W_{DECAY}$  is the consumed power during current decay.
- $R_{ONH}$  is the upper P-channel DMOS ON-resistance.
- $R_{ONL}$  is the lower N-channel DMOS ON-resistance.
- $I_{OUT}$  is the motor output current value.
- $on\_duty$  is PWM on duty =  $t_{ON} / t_{CHOP}$
- "2" is the H bridge A and B.

$t_{ON}$  varies depending on the L and R values of the motor coil and the current set value. Confirm by actual measurement, or make an approximate calculation.

$t_{CHOP}$  is the chopping period, which is determined by the internal timer. Refer to [P.9](#), [10](#) for details.

IC number	Upper Pch DMOS ON Resistance $R_{ONH}[\Omega]$ (Typ)	Lower Nch DMOS ON Resistance $R_{ONL}[\Omega]$ (Typ)
BD63888MUV	0.70	0.30

$$W_{total} = W_{VCC} + W_{DMOS} \quad [W]$$

$$T_j = T_a + \theta_{ja} \times W_{total} \quad [^\circ C]$$

where:

- $W_{total}$  is the consumed total power of IC.
- $T_j$  is the junction temperature.
- $T_a$  is the air temperature.
- $\theta_{ja}$  is the thermal resistance value.

However, the thermal resistance value  $\theta_{ja}$  [°C/W] differs greatly depending on circuit board conditions. The calculated values above are only theoretical. For actual thermal design, perform sufficient thermal evaluation for the application board used, and create the thermal design with enough margin not to exceed  $T_{jmax}=150$ °C. Although unnecessary with normal use, if the IC is to be used under especially strict heat conditions, consider externally attaching a Schottky diode between the motor output pin and GND to abate heat from the IC.

Power Dissipation – continued

Temperature Monitoring

In respect of BD63888MUV, there is a way to directly measure the approximate chip temperature by using the TESTx<sup>(Note 25)</sup> pin with a protection diode for prevention from electrostatic discharge. However, temperature monitor using this TESTx pin is only for evaluation and experimenting, and must not be used in actual usage conditions.

(Note 25) x=1 or 2

- (1) Measure the pin voltage when a current of  $I_{DIODE}=50 \mu A$  flows from the TESTx pin to the GND, without supplying VBB1, VBB2 to the IC. This is measurement of the  $V_F$  voltage inside the diode.
- (2) Measure the temperature characteristics of this pin voltage. ( $V_F$  has a linear negative temperature factor against the temperature.) With the results of these temperature characteristics, chip temperature can calibrate from the TESTx pin voltage.
- (3) Supply VBB1, VBB2, confirm the TESTx pin voltage while running the motor, and calculate approximately the chip temperature from the results of (2).

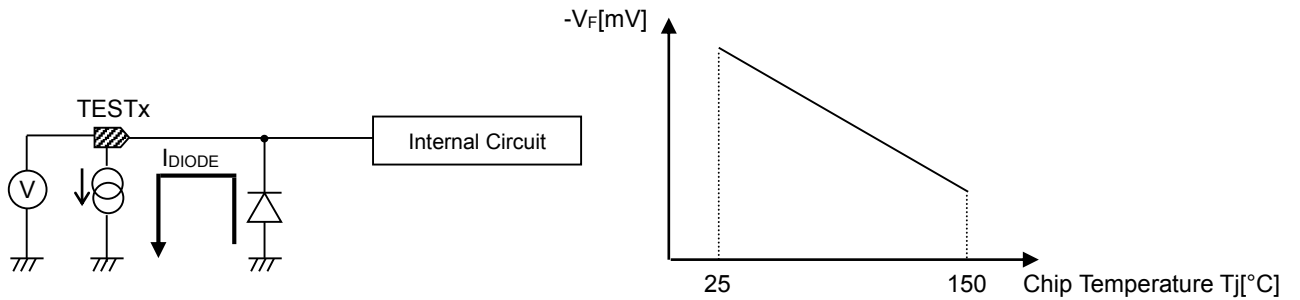

Figure 7. Model Diagram for Measuring Chip Temperature

Application Example

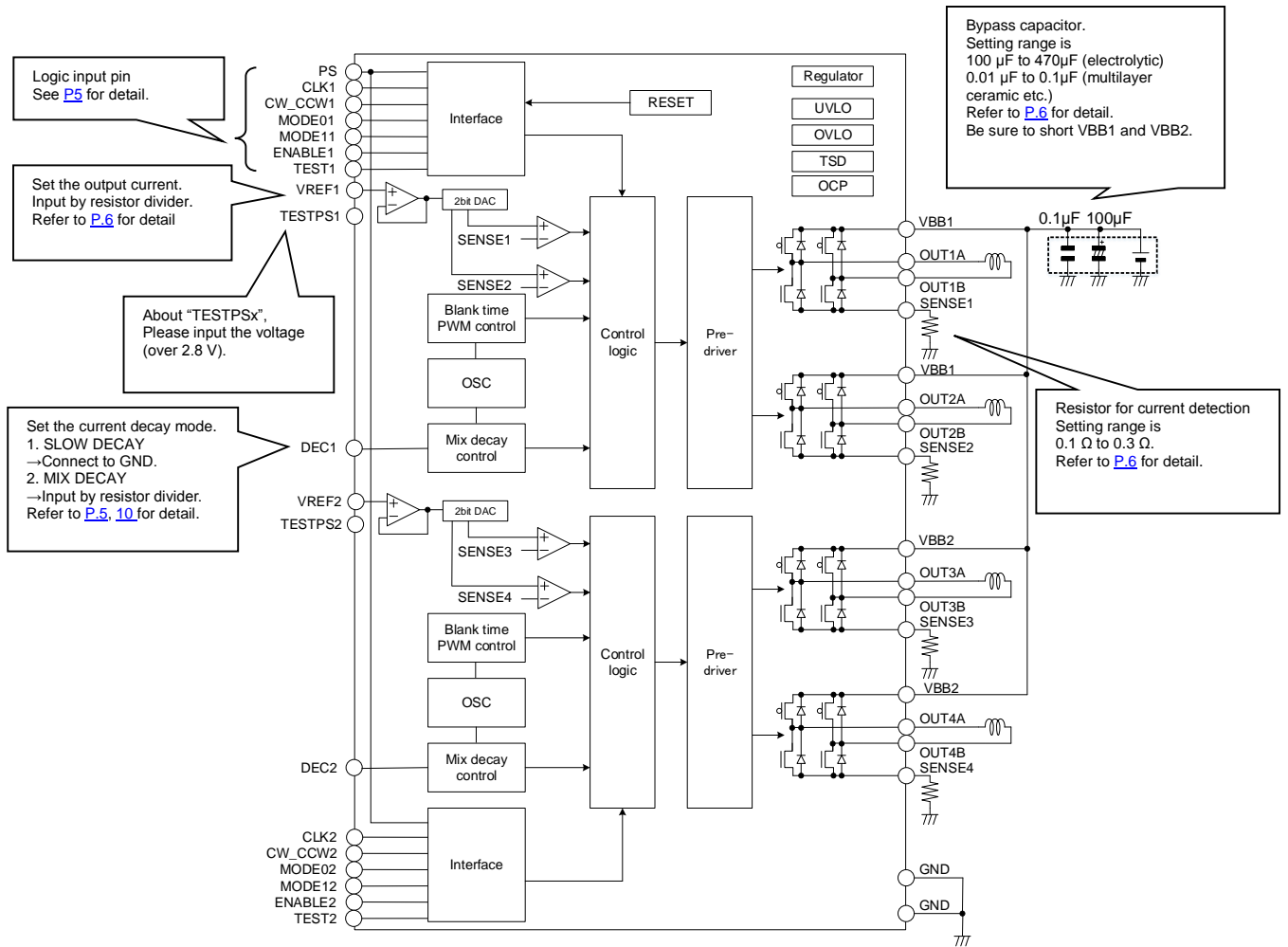
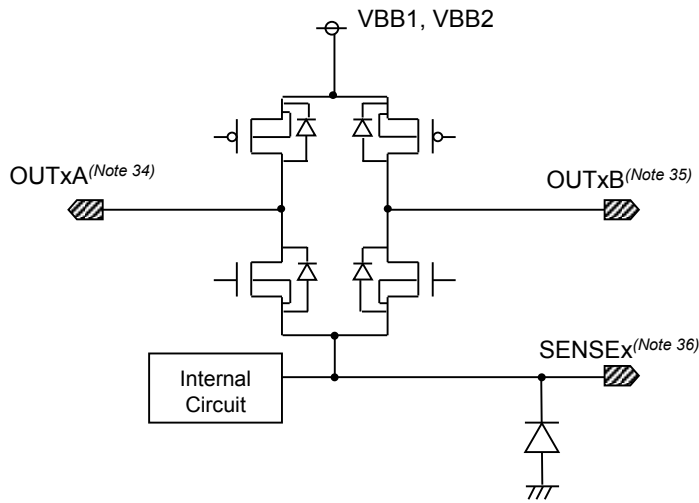
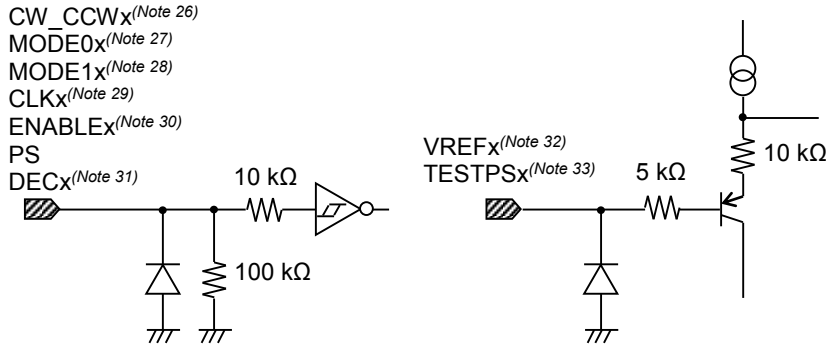

Figure 8. BD63888MUV Block Diagram and Applied Circuit Diagram

I/O Equivalence Circuit



- (Note 26) x=1 or 2
- (Note 27) x=1 or 2
- (Note 28) x=1 or 2
- (Note 29) x=1 or 2
- (Note 30) x=1 or 2
- (Note 31) x=1 or 2
- (Note 32) x=1 or 2
- (Note 33) x=1 or 2
- (Note 34) x=1, 2, 3 or 4
- (Note 35) x=1, 2, 3 or 4
- (Note 36) x=1, 2, 3 or 4

## Operational Notes

### 1. Reverse Connection of Power Supply

Connecting the power supply in reverse polarity can damage the IC. Take precautions against reverse polarity when connecting the power supply, such as mounting an external diode between the power supply and the IC's power supply pins.

### 2. Power Supply Lines

Design the PCB layout pattern to provide low impedance supply lines. Furthermore, connect a capacitor to ground at all power supply pins. Consider the effect of temperature and aging on the capacitance value when using electrolytic capacitors.

### 3. Ground Voltage

Ensure that no pins are at a voltage below that of the ground pin at any time, even during transient condition.

### 4. Ground Wiring Pattern

When using both small-signal and large-current ground traces, the two ground traces should be routed separately but connected to a single ground at the reference point of the application board to avoid fluctuations in the small-signal ground caused by large currents. Also ensure that the ground traces of external components do not cause variations on the ground voltage. The ground lines must be as short and thick as possible to reduce line impedance.

### 5. Recommended Operating Conditions

The function and operation of the IC are guaranteed within the range specified by the recommended operating conditions. The characteristic values are guaranteed only under the conditions of each item specified by the electrical characteristics.

### 6. Inrush Current

When power is first supplied to the IC, it is possible that the internal logic may be unstable and inrush current may flow instantaneously due to the internal powering sequence and delays, especially if the IC has more than one power supply. Therefore, give special consideration to power coupling capacitance, power wiring, width of ground wiring, and routing of connections.

### 7. Operation Under Strong Electromagnetic Field

Operating the IC in the presence of a strong electromagnetic field may cause the IC to malfunction.

### 8. Testing on Application Boards

When testing the IC on an application board, connecting a capacitor directly to a low-impedance output pin may subject the IC to stress. Always discharge capacitors completely after each process or step. The IC's power supply should always be turned off completely before connecting or removing it from the test setup during the inspection process. To prevent damage from static discharge, ground the IC during assembly and use similar precautions during transport and storage.

### 9. Inter-pin Short and Mounting Errors

Ensure that the direction and position are correct when mounting the IC on the PCB. Incorrect mounting may result in damaging the IC. Avoid nearby pins being shorted to each other especially to ground, power supply and output pin. Inter-pin shorts could be due to many reasons such as metal particles, water droplets (in very humid environment) and unintentional solder bridge deposited in between pins during assembly to name a few.

### 10. Unused Input Pins

Input pins of an IC are often connected to the gate of a MOS transistor. The gate has extremely high impedance and extremely low capacitance. If left unconnected, the electric field from the outside can easily charge it. The small charge acquired in this way is enough to produce a significant effect on the conduction through the transistor and cause unexpected operation of the IC. So unless otherwise specified, unused input pins should be connected to the power supply or ground line.

Operational Notes – continued

11. Regarding the Input Pin of the IC

This monolithic IC contains P+ isolation and P substrate layers between adjacent elements in order to keep them isolated. P-N junctions are formed at the intersection of the P layers with the N layers of other elements, creating a parasitic diode or transistor. For example (refer to figure below):

When GND > Pin A and GND > Pin B, the P-N junction operates as a parasitic diode.  
 When GND > Pin B, the P-N junction operates as a parasitic transistor.

Parasitic diodes inevitably occur in the structure of the IC. The operation of parasitic diodes can result in mutual interference among circuits, operational faults, or physical damage. Therefore, conditions that cause these diodes to operate, such as applying a voltage lower than the GND voltage to an input pin (and thus to the P substrate) should be avoided.

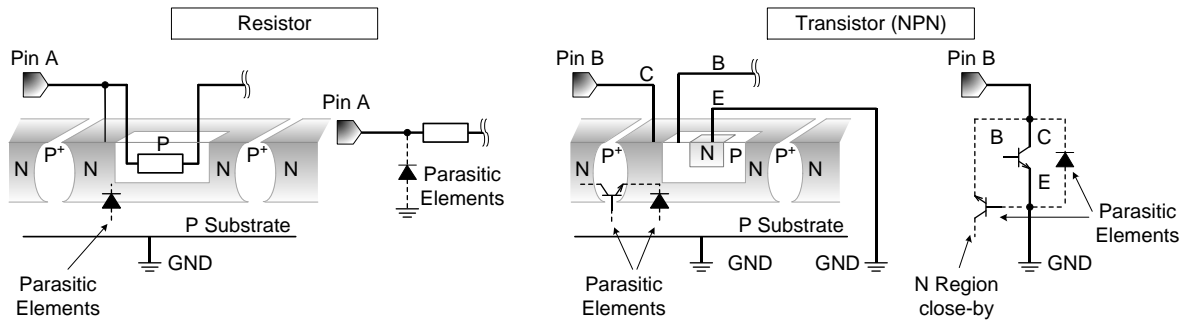

Figure 9. Example of monolithic IC structure

12. Ceramic Capacitor

When using a ceramic capacitor, determine a capacitance value considering the change of capacitance with temperature and the decrease in nominal capacitance due to DC bias and others.

13. Thermal Shutdown Circuit(TSD)

This IC has a built-in thermal shutdown circuit that prevents heat damage to the IC. Normal operation should always be within the IC's maximum junction temperature rating. If however the rating is exceeded for a continued period, the junction temperature ( $T_j$ ) will rise which will activate the TSD circuit that will turn OFF power output pins. The IC should be powered down and turned ON again to resume normal operation because the TSD circuit keeps the outputs at the OFF state even if the  $T_j$  falls below the TSD threshold.

Note that the TSD circuit operates in a situation that exceeds the absolute maximum ratings and therefore, under no circumstances, should the TSD circuit be used in a set design or for any purpose other than protecting the IC from heat damage.

14. Over Current Protection Circuit (OCP)

This IC incorporates an integrated overcurrent protection circuit that is activated when the load is shorted. This protection circuit is effective in preventing damage due to sudden and unexpected incidents. However, the IC should not be used in applications characterized by continuous operation or transitioning of the protection circuit.

Ordering Information

B D 6 3 8 8 8 M U V - E 2

Part Number

Package  
MUV : VQFN036V6060

Packing and Forming specification  
E2 : Embossed tape and reel

Marking Diagram

VQFN036V6060 (TOP VIEW)

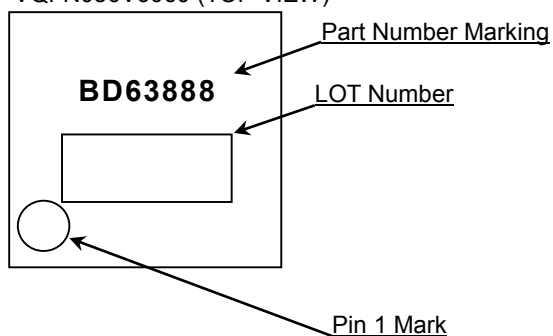

Physical Dimension and Packing Information

Package Name	VQFN036V6060
--------------	--------------

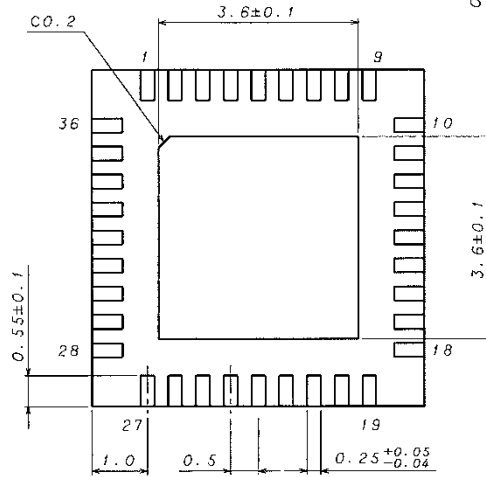
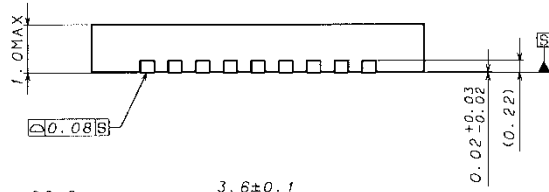
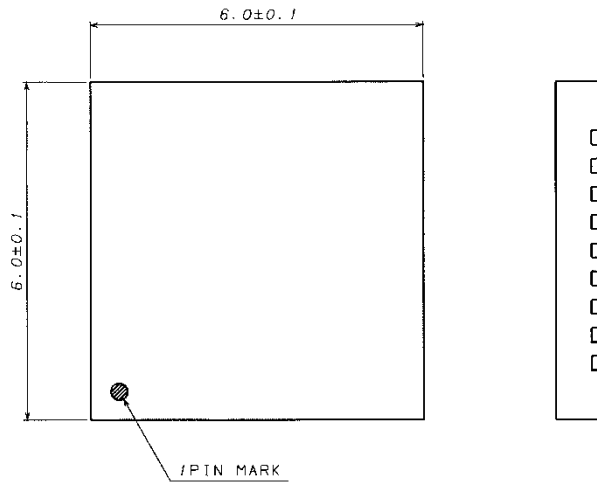

(UNIT: mm)

PKG: VQFN036V6060  
Drawing No. EX472-5001

< Tape and Reel Information >

Tape	Embossed carrier tape (with dry pack)
Quantity	2000pcs
Direction of feed	E2 The direction is the pin 1 of product is at the upper left when you hold reel on the left hand and you pull out the tape on the right hand

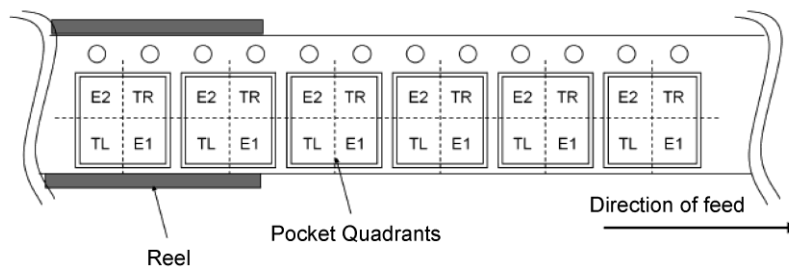

## Revision History

Date	Revision	Changes
27.Apr.2018	001	New Release

# Notice

## Precaution on using ROHM Products

- Our Products are designed and manufactured for application in ordinary electronic equipment (such as AV equipment, OA equipment, telecommunication equipment, home electronic appliances, amusement equipment, etc.). If you intend to use our Products in devices requiring extremely high reliability (such as medical equipment <sup>(Note 1)</sup>, transport equipment, traffic equipment, aircraft/spacecraft, nuclear power controllers, fuel controllers, car equipment including car accessories, safety devices, etc.) and whose malfunction or failure may cause loss of human life, bodily injury or serious damage to property ("Specific Applications"), please consult with the ROHM sales representative in advance. Unless otherwise agreed in writing by ROHM in advance, ROHM shall not be in any way responsible or liable for any damages, expenses or losses incurred by you or third parties arising from the use of any ROHM's Products for Specific Applications.

(Note1) Medical Equipment Classification of the Specific Applications

JAPAN	USA	EU	CHINA
CLASS III	CLASS III	CLASS II b	CLASS III
CLASS IV		CLASS III	

- ROHM designs and manufactures its Products subject to strict quality control system. However, semiconductor products can fail or malfunction at a certain rate. Please be sure to implement, at your own responsibilities, adequate safety measures including but not limited to fail-safe design against the physical injury, damage to any property, which a failure or malfunction of our Products may cause. The following are examples of safety measures:
  - Installation of protection circuits or other protective devices to improve system safety
  - Installation of redundant circuits to reduce the impact of single or multiple circuit failure
- Our Products are designed and manufactured for use under standard conditions and not under any special or extraordinary environments or conditions, as exemplified below. Accordingly, ROHM shall not be in any way responsible or liable for any damages, expenses or losses arising from the use of any ROHM's Products under any special or extraordinary environments or conditions. If you intend to use our Products under any special or extraordinary environments or conditions (as exemplified below), your independent verification and confirmation of product performance, reliability, etc. prior to use, must be necessary:
  - Use of our Products in any types of liquid, including water, oils, chemicals, and organic solvents
  - Use of our Products outdoors or in places where the Products are exposed to direct sunlight or dust
  - Use of our Products in places where the Products are exposed to sea wind or corrosive gases, including Cl<sub>2</sub>, H<sub>2</sub>S, NH<sub>3</sub>, SO<sub>2</sub>, and NO<sub>2</sub>
  - Use of our Products in places where the Products are exposed to static electricity or electromagnetic waves
  - Use of our Products in proximity to heat-producing components, plastic cords, or other flammable items
  - Sealing or coating our Products with resin or other coating materials
  - Use of our Products without cleaning residue of flux (even if you use no-clean type fluxes, cleaning residue of flux is recommended); or Washing our Products by using water or water-soluble cleaning agents for cleaning residue after soldering
  - Use of the Products in places subject to dew condensation
- The Products are not subject to radiation-proof design.
- Please verify and confirm characteristics of the final or mounted products in using the Products.
- In particular, if a transient load (a large amount of load applied in a short period of time, such as pulse. is applied, confirmation of performance characteristics after on-board mounting is strongly recommended. Avoid applying power exceeding normal rated power; exceeding the power rating under steady-state loading condition may negatively affect product performance and reliability.
- De-rate Power Dissipation depending on ambient temperature. When used in sealed area, confirm that it is the use in the range that does not exceed the maximum junction temperature.
- Confirm that operation temperature is within the specified range described in the product specification.
- ROHM shall not be in any way responsible or liable for failure induced under deviant condition from what is defined in this document.

## Precaution for Mounting / Circuit board design

- When a highly active halogenous (chlorine, bromine, etc.) flux is used, the residue of flux may negatively affect product performance and reliability.
- In principle, the reflow soldering method must be used on a surface-mount products, the flow soldering method must be used on a through hole mount products. If the flow soldering method is preferred on a surface-mount products, please consult with the ROHM representative in advance.

For details, please refer to ROHM Mounting specification

### Precautions Regarding Application Examples and External Circuits

1. If change is made to the constant of an external circuit, please allow a sufficient margin considering variations of the characteristics of the Products and external components, including transient characteristics, as well as static characteristics.
2. You agree that application notes, reference designs, and associated data and information contained in this document are presented only as guidance for Products use. Therefore, in case you use such information, you are solely responsible for it and you must exercise your own independent verification and judgment in the use of such information contained in this document. ROHM shall not be in any way responsible or liable for any damages, expenses or losses incurred by you or third parties arising from the use of such information.

### Precaution for Electrostatic

This Product is electrostatic sensitive product, which may be damaged due to electrostatic discharge. Please take proper caution in your manufacturing process and storage so that voltage exceeding the Products maximum rating will not be applied to Products. Please take special care under dry condition (e.g. Grounding of human body / equipment / solder iron, isolation from charged objects, setting of Ionizer, friction prevention and temperature / humidity control).

### Precaution for Storage / Transportation

1. Product performance and soldered connections may deteriorate if the Products are stored in the places where:
  - [a] the Products are exposed to sea winds or corrosive gases, including Cl<sub>2</sub>, H<sub>2</sub>S, NH<sub>3</sub>, SO<sub>2</sub>, and NO<sub>2</sub>
  - [b] the temperature or humidity exceeds those recommended by ROHM
  - [c] the Products are exposed to direct sunshine or condensation
  - [d] the Products are exposed to high Electrostatic
2. Even under ROHM recommended storage condition, solderability of products out of recommended storage time period may be degraded. It is strongly recommended to confirm solderability before using Products of which storage time is exceeding the recommended storage time period.
3. Store / transport cartons in the correct direction, which is indicated on a carton with a symbol. Otherwise bent leads may occur due to excessive stress applied when dropping of a carton.
4. Use Products within the specified time after opening a humidity barrier bag. Baking is required before using Products of which storage time is exceeding the recommended storage time period.

### Precaution for Product Label

A two-dimensional barcode printed on ROHM Products label is for ROHM's internal use only.

### Precaution for Disposition

When disposing Products please dispose them properly using an authorized industry waste company.

### Precaution for Foreign Exchange and Foreign Trade act

Since concerned goods might be fallen under listed items of export control prescribed by Foreign exchange and Foreign trade act, please consult with ROHM in case of export.

### Precaution Regarding Intellectual Property Rights

1. All information and data including but not limited to application example contained in this document is for reference only. ROHM does not warrant that foregoing information or data will not infringe any intellectual property rights or any other rights of any third party regarding such information or data.
2. ROHM shall not have any obligations where the claims, actions or demands arising from the combination of the Products with other articles such as components, circuits, systems or external equipment (including software).
3. No license, expressly or implied, is granted hereby under any intellectual property rights or other rights of ROHM or any third parties with respect to the Products or the information contained in this document. Provided, however, that ROHM will not assert its intellectual property rights or other rights against you or your customers to the extent necessary to manufacture or sell products containing the Products, subject to the terms and conditions herein.

### Other Precaution

1. This document may not be reprinted or reproduced, in whole or in part, without prior written consent of ROHM.
2. The Products may not be disassembled, converted, modified, reproduced or otherwise changed without prior written consent of ROHM.
3. In no event shall you use in any way whatsoever the Products and the related technical information contained in the Products or this document for any military purposes, including but not limited to, the development of mass-destruction weapons.
4. The proper names of companies or products described in this document are trademarks or registered trademarks of ROHM, its affiliated companies or third parties.

**General Precaution**

1. Before you use our Products, you are requested to carefully read this document and fully understand its contents. ROHM shall not be in any way responsible or liable for failure, malfunction or accident arising from the use of any ROHM's Products against warning, caution or note contained in this document.
2. All information contained in this document is current as of the issuing date and subject to change without any prior notice. Before purchasing or using ROHM's Products, please confirm the latest information with a ROHM sales representative.
3. The information contained in this document is provided on an "as is" basis and ROHM does not warrant that all information contained in this document is accurate and/or error-free. ROHM shall not be in any way responsible or liable for any damages, expenses or losses incurred by you or third parties resulting from inaccuracy or errors of or concerning such information.