

Material declaration

No.	NAME	Description
① A	基座	PPA 热塑性塑胶[黑色]
② B	内芯针	H62 黄铜 $\phi 2/2.5$ [镀银]
③ C	静态端子	黄铜 H62[镀银/锡基 50u" min]
④ D	动态端子	磷铜 H65[镀银/锡基 50u" min]
⑤ E	外壳	黄铜 H62[镀银/锡基 50u" min]

REVISION

LTR	DESCRIPTION	DATE	APP
A0	NEW RELEASE	05/20/2020	PECK

P.C.B LAYOUT

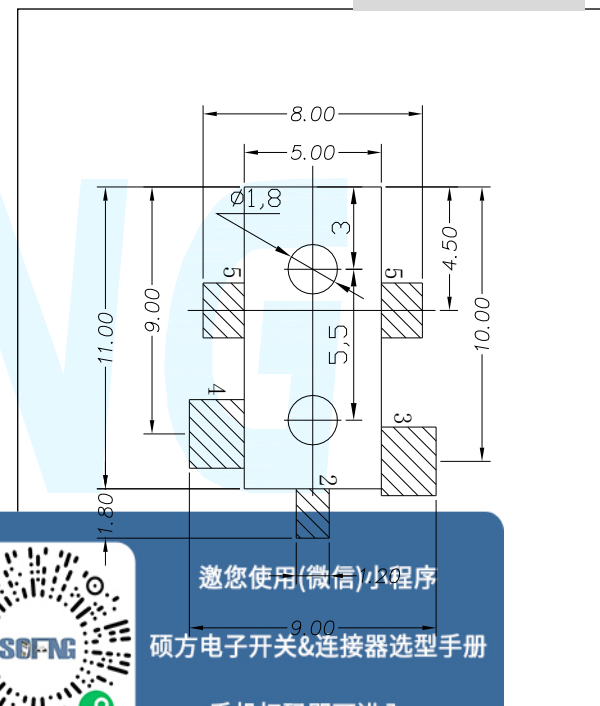

邀您使用(微信)小程序
硕方电子开关&连接器选型手册
手机扫码即可进入...

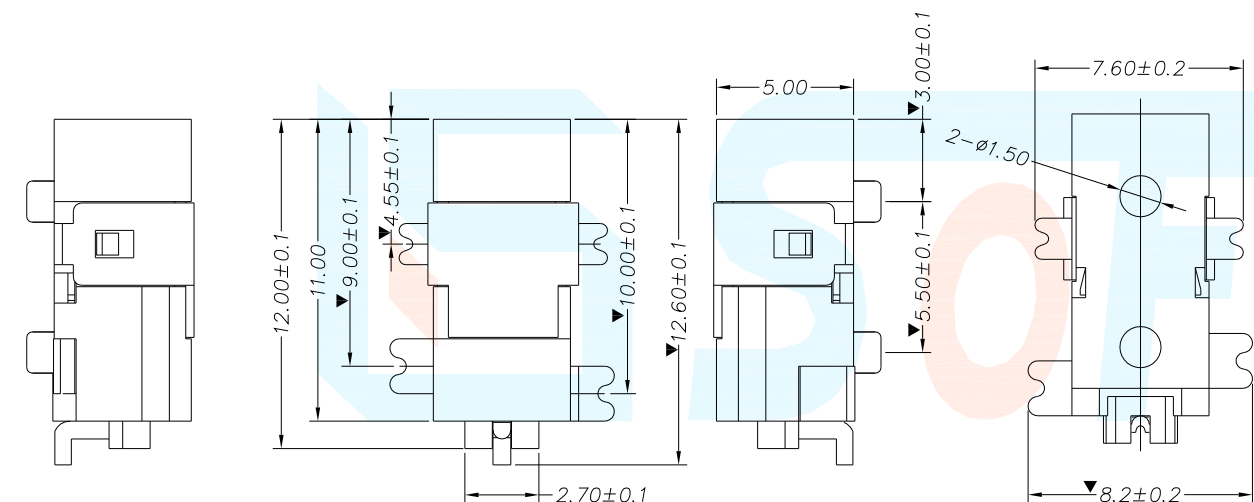

		LEVEL	
PROJECT		A[better product]	B[average product]
Electrical Properties	Contact Rating	1A, 24V DC	
	Initial Contact Resistance	50mΩ max.	
	Insulation Resistance	100MΩ min.500V DC	Skey/PD: 100MΩ min.300V DC
Durable Performance	Withstand Voltage	500V AC for 1 minute	350 V AC for 1 minut
	There No Load	6,000 Cycles	5,000 Cycles
	Rated Load	5,000 Cycles	4,000 Cycles
Storage temp.		-35°C~+85°C(Operating Temp:)	
Operating Force		IF: 35N MAX. (EF: 10.0N MIN.)	
Heat Rrsistance		IR Reflow: 255°C, 5sec. Manual: 350°C, 3sec.	

DIMENSION CLASSIFICATION		台湾硕方精密电子科技有限公司		TAIWAN SOFNG PRECISION ELECTRONIC CO., LTD		開關, 连接器	
■ : CRITICAL		TITLE		DC-011C 小型DC电源插座		SOFNG	
☒ : MAJOR		TOLERANCE TABLE		卧贴式带柱/直径2.6mm		SERIES SD106	
.X	± 0.40	PART NO.	DC-011C				
.XX	± 0.25	APPROVED	Peck	DWG NO.	SOF-G006		
.XXX	± 0.10	CHECKED	Paul	SCALE	1:1	UNIT	mm
ANGLE	± 2°	DRAWIN	David	REV	AO	SHEET NO.	1/1

