

INSTRUCTION SHEET

Coded Magnetic Switches HS7A-DMP

HS9Z-ZP1 HS7A-DMP

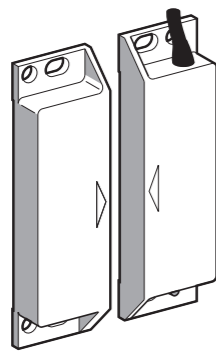

Confirm that the delivered product is what you have ordered. Read this instruction sheet to make sure of correct operation. Make sure that the instruction sheet is kept by the end user.

The products have been designed in accordance with the standards in effect : IEC 60947-5-1, EN 292, EN 60204-1 to ensure the safety of machine operators and machine operating reliability, and have obtained the UL/CSA certifications.

SAFETY NOTE

CAUTION

The use of the safety relay modules is required for the monitoring of the coded magnetic safety switches.

When correctly installed and connected to the HR1S safety relay modules they produce a category 4 control circuit per EN ISO 13849-1 (2 redundant contacts monitored by one HR1S safety relay module or FS series safety controller. See user's manual for wiring with safety controller).

Use the safety switches for an interlocking device in compliance with laws and regulations of the country in which it is being used.

1 Specifications

Conforming to standards	IEC / EN 60947-5-1 EN ISO / ISO 14119 UL 508, CSA C22.2 No.14
Interlocking device Type / the level of coded	Type 4 interlocking device / low level coded actuator (EN ISO 14119)
Ambient air temperature	Operation : -13° F to 185° F (-25°C+85°C) (no freezing) Storage : -40° F to 185° F (-40°C+85°C) (no freezing)
Vibration resistance	10 gn (10-150 Hz) conforming to IEC 60068-2-6
Shock resistance	30 gn (11 ms) conforming to IEC 60068-2-7
Protection against electric shock	Class II as per IEC 60536
Degree of protection	IP67
Degree of pollution	3, conforming to IEC / EN 60947-5-1
Rated operating characteristics	Ue = 24VDC Ie = 100 mA
Protection (using without safety relay module)	500 mA gG (gL) cartridge fuse (use type CC in the United States)
Repeat accuracy	≤10%
Hysteresis	≤20%
Frequency of operating cycle	150 Hz
Drop out voltage	I=10mA 0,1V without LED; 2,4V with LED I=100mA 1V without LED; 4,2V with LED
Functional switches	Closing - Opening
Cable connection	By cable 6 x AWG 23 (0,25mm ²) length 78.74 in, 196.85 in (2m, 5m), depending on model

2 Dimensions (mm)

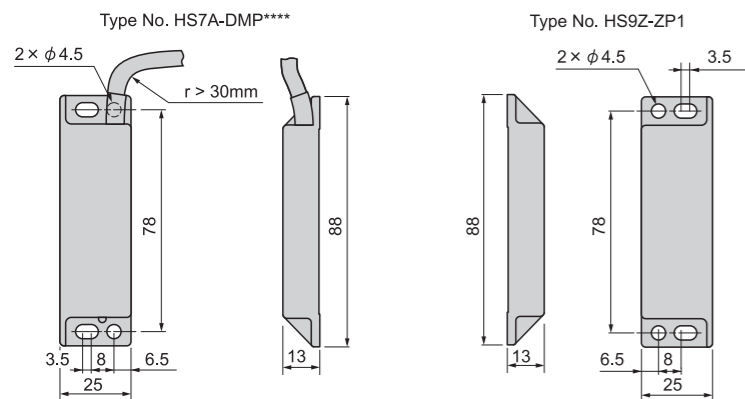

3 Operation

Functional directions - Minimum distance between the safety switch and the magnet

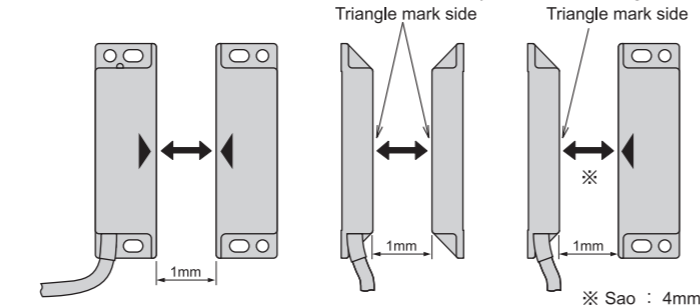

Contact status
 -Contact closed (1)
 -Contact open (0)
 -Transient state

Sao : Assured Operation Distance
 Sar : Assured Release Distance

Operation chart

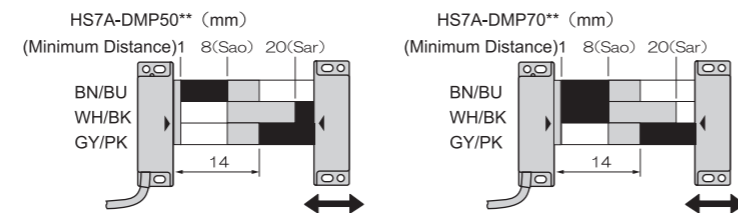

Sensing area

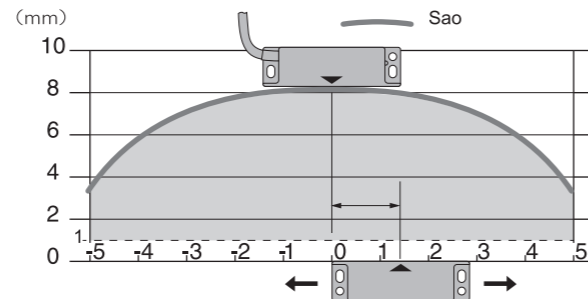

4 Mounting

Required arrangement with ferromagnetic mounting support

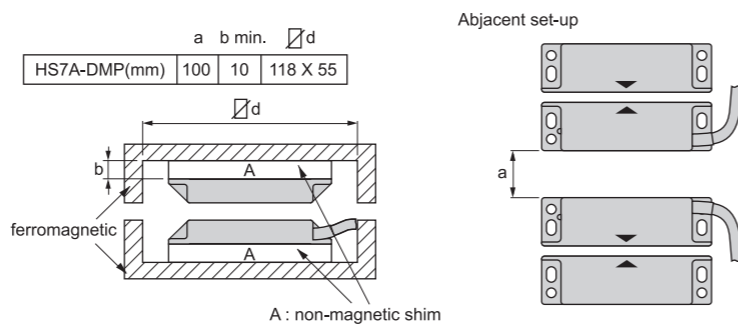

Tightening torque, Tightening capacity

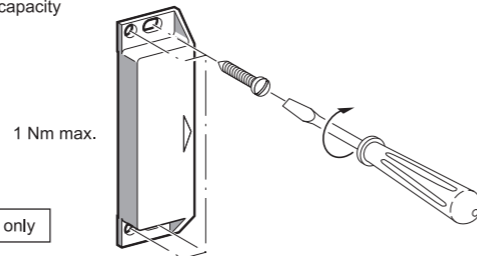

Use non-magnetic screws only

Utilization precautions

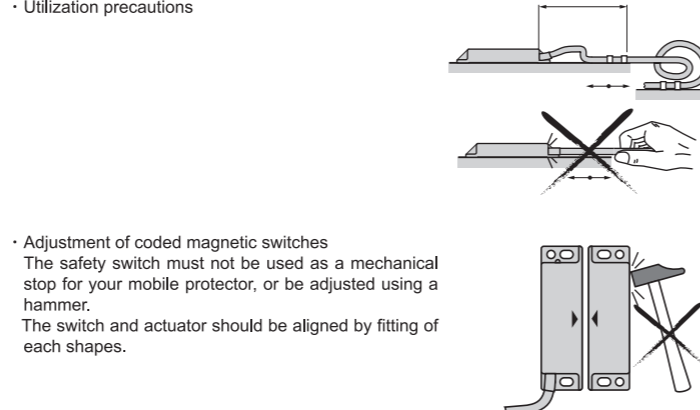

CAUTION

≥ 0.3mT

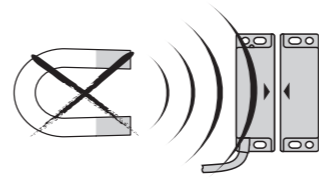

5 Wiring diagram

WARNING

HAZARDOUS VOLTAGE
 Disconnect all power before working on equipment.
 Electric shock will result in death or serious injury.

* Illustration of contacts with magnet present

Cat. 4 / PL=e (EN ISO 13849-1) / SIL3
 - HR1S-DMB + HS7A-DMP50** (NC+NC+NO) + HS9Z-ZP1

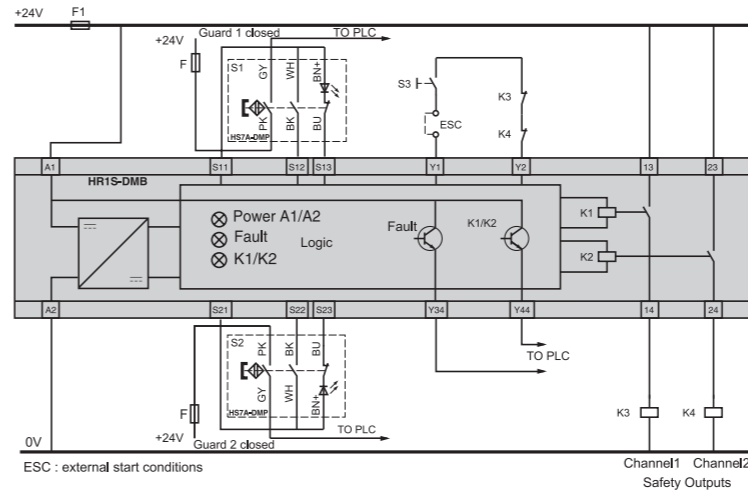

Cat. 3 / PL=d (EN ISO 13849-1) / SIL2 - HR1S-DME

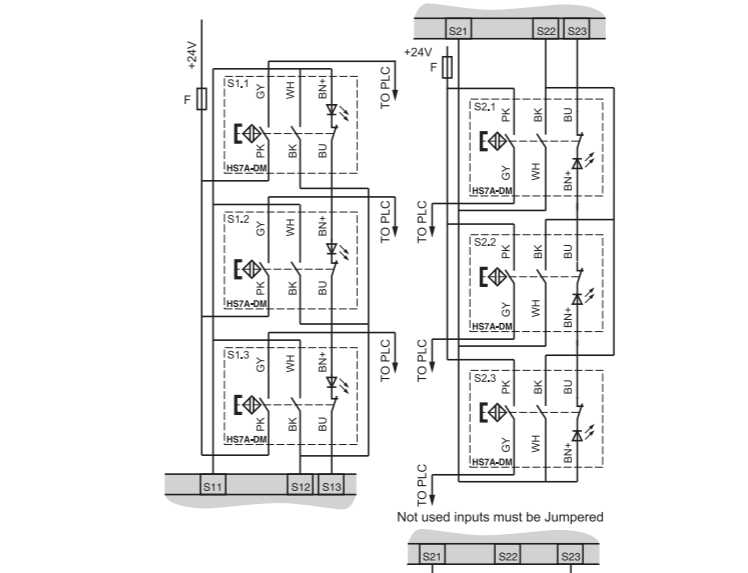

Cat. 4 / PL=e (EN ISO 13849-1) / SIL3
 - HR1S-DME + HS7A-DMP50** (NC+NC+NO) + HS9Z-ZP1

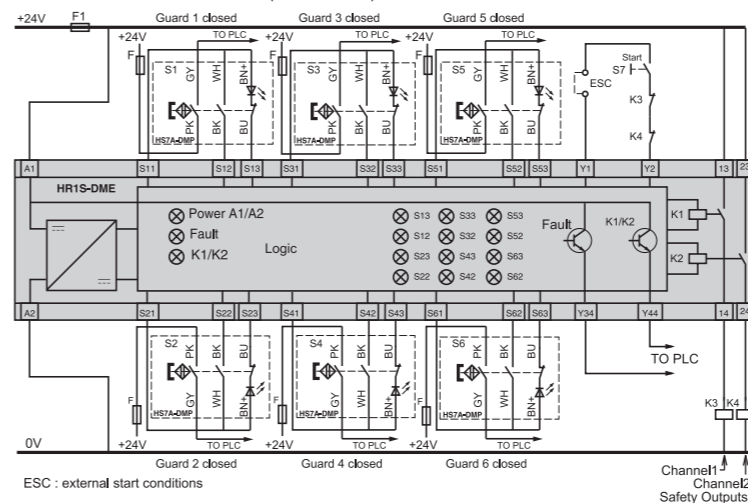

Cat. 3 / PL=d (EN ISO 13849-1) / SIL2 - HR1S-DME

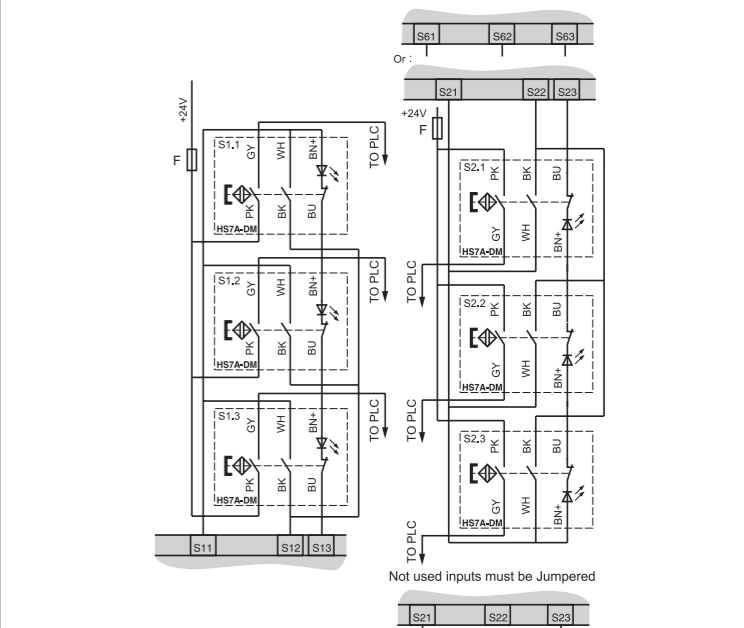

Cat. 4 / PL=e (EN ISO 13849-1) / SIL3
 - HR1S-AF + HS7A-DMP70** (NO+NO+NC) + HS9Z-ZP1

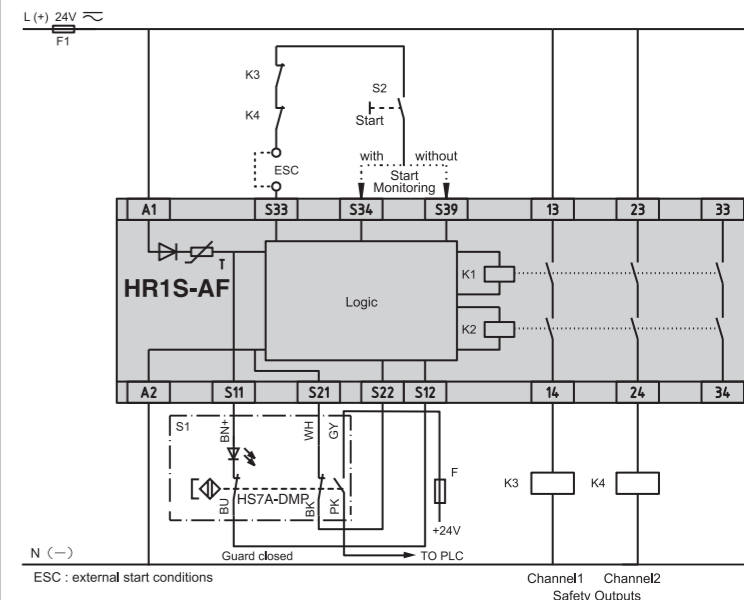

Connectable HS7A-DMP per Input.

	HS7A-DMP50**		HS7A-DMP70**	
	without LED	with LED	without LED	with LED
HR1S-DMB/DME	6	3	6	1
HR1S-AF			6	1

Type

Type No.	LED	Cable	Contact	Type No.	LED	Cable	Contact
HS7A-DMP5002	without		NO	HS7A-DMP7002	without		NO
HS7A-DMP5012	with	2m	NC	HS7A-DMP7012	with	2m	+
HS7A-DMP5005	without		NC	HS7A-DMP7005	without		NO
HS7A-DMP5015	with	5m	NC	HS7A-DMP7015	with	5m	+

IDEC CORPORATION

http://www.idec.com
2015.9

DECLARATION OF CONFORMITY

We, IDEC CORPORATION 6-64, Nishimiyahara 2-chome Yodogawa-ku, Osaka 532-0004, Japan declare under our sole responsibility that the product:
 Description: Non-contact Safety Switch
 Series Name: HS7A Series
 Model No.: HS7A-DMP50** (** = 02, 12, 05, or 15), HS7A-DMP70** (** = 02, 12, 05, or 15)
 to which this declaration relates is in conformity with the EC Directive on the following standard(s) or other normative document(s). In case of alteration of the product, not agreed upon by us, this declaration will lose its validity.
 Applicable EC Directive: Low Voltage Directive (2006/95/EC)
 EC Directive of Electromagnetic Compatibility (2004/108/EC)
 Machinery Directive (2006/42/EC)

Applicable Standard(s) : EN ISO 13849-1, EN ISO 14119, EN 60204-1, EN 62061, EN 60947-1, EN 60947-5-1
 Authorized Representative in EU : IDEC ELEKTROTECHNIK GmbH Heselstuecken 8, 22453 Hamburg, Germany

Mouser Electronics

Authorized Distributor

Click to View Pricing, Inventory, Delivery & Lifecycle Information:

IDEC:

[HS7A-DMP7012](#) [HS7A-DMP5002](#) [HS7A-DMP5005](#) [HS7A-DMP5012](#) [HS7A-DMP5015](#) [HS7A-DMP7002](#) [HS7A-DMP7005](#) [HS7A-DMP7015](#)