

HSMW-C340

White Surface-Mount 0.4-mm Right-Angle JLED

Description

The Broadcom[®] HSMW-C340 is a side-emitting surface-mount LED. This LED is available in a package dimensions of 3.7 mm × 0.9mm × 0.43 mm. The low package profile allows efficient optical coupling to thin light guides for applications, such as display backlighting, which requires high brightness and uniform light distribution.

This LED is available in white color and uses high brightness InGaN LED material. This LED uses silicone encapsulation, which significantly enhances its lifetime performance.

This chipLED is compatible with reflow soldering process. For easy pick-and-place, the parts are packed in tape and reel. Every reel is shipped with a single intensity and color bin for better uniformity control.

Features

- LEDs with InGaN die
- White emitting color
- Compatible with reflow soldering
- Available in 12-mm tape and 7-in. diameter reel

Applications

- Backlighting
- Indicator

CAUTION! HSMW-C340 LEDs are Class 1A ESD sensitive per JESD22-A114C.01. Please observe appropriate precautions during handling and processing. Refer to Application Note AN-1142 for additional details

Figure 1: Package Dimensions

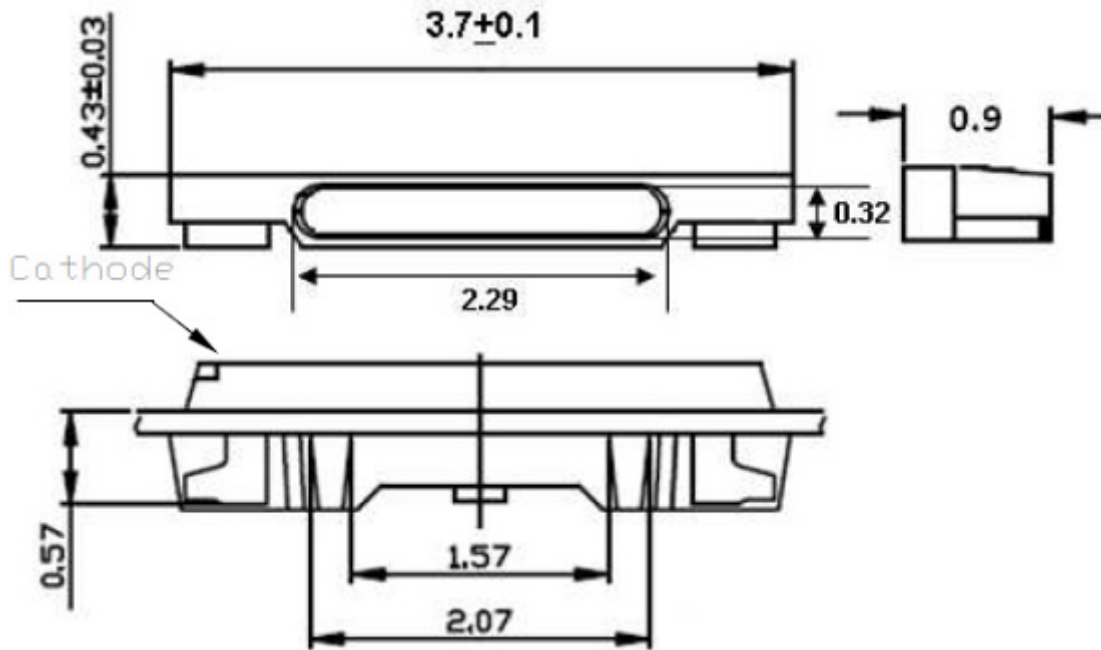

NOTE:

1. All dimensions are in millimeters.
2. Tolerance is ± 0.1 mm unless otherwise specified.

Device Selection Guide

Part Number	Dimension (mm)	Color	Die Technology	Package Description
HSMW-C340	3.7 (L) × 0.9 (W) × 0.43 (H)	White	InGaN	Untinted, Diffused

Absolute Maximum Ratings at $T_A = 25^\circ\text{C}$

Parameter	HSMW-C340	Units
DC Forward Current ^a	30	mA
Peak Forward Current ^b	100	mA
Power Dissipation	120	mW
Reverse Voltage ($I_R = 100 \mu\text{A}$)	5	V
LED Junction Temperature	110	$^\circ\text{C}$
Operating Temperature Range	-40 to +85	$^\circ\text{C}$
Storage Temperature Range	-40 to +85	$^\circ\text{C}$

a. Derate as shown in Figure 5.

b. Duty factor = 10%, frequency = 1 kHz.

Electrical Characteristics at $T_A = 25^\circ\text{C}$

Part Number	Forward Voltage V_F (Volts) at $I_F = 20\text{ mA}$		Reverse Voltage ^a V_R (Volts) at $I_R = 100\ \mu\text{A}$	Thermal Resistance $R\theta_{JP}$ ($^\circ\text{C}/\text{W}$)
	Typ.	Max.	Min.	Typ.
HSMW-C340	3.3	3.9	5	450

a. Indicates product final test condition. Long-term reverse bias is not recommended.

Optical Characteristics at $T_A = 25^\circ\text{C}$

Part Number	Luminous Intensity I_V^a (mcd) at 20 mA	Typical Chromaticity Coordinate ^b Tolerance = ± 0.02		Viewing Angle $2\theta_{1/2}^c$ (Degrees)
	Min.	X	Y	Typ.
HSMW-C340	1000	0.31	0.31	120

- a. The luminous intensity I_V is measured at the peak of the spatial radiation pattern which may not be aligned with the mechanical axis of the LED package.
- b. The chromaticity coordinates are derived from the CIE 1931 Chromaticity Diagram and represents the perceived color of the device.
- c. $\theta_{1/2}$ is the off-axis angle where the luminous intensity is $\frac{1}{2}$ the peak intensity.

Bin Information

Light Intensity (I_v) Bin Limits

Bin ID	Intensity (mcd)	
	Minimum	Maximum
W1	1000	1200
W2	1200	1400
W3	1400	1600
W4	1600	1800
W5	1800	2000
W6	2000	2200
W7	2200	2400
W8	2400	2600
W9	2600	2800

Tolerance $\pm 15\%$.

Color Bins (BIN)

Bin ID	Limits (Chromaticity Coordinates)					
		X	Y	Z	u'	v'
C11	X	0.290	0.297	0.297	0.290	
	Y	0.306	0.316	0.283	0.274	
C12	X	0.297	0.303	0.303	0.297	
	Y	0.316	0.326	0.293	0.283	
C13	X	0.303	0.310	0.310	0.303	
	Y	0.326	0.336	0.303	0.293	
C21	X	0.290	0.297	0.297	0.290	
	Y	0.274	0.283	0.251	0.241	
C22	X	0.297	0.303	0.303	0.297	
	Y	0.283	0.293	0.261	0.251	
C23	X	0.303	0.310	0.310	0.303	
	Y	0.293	0.303	0.271	0.261	
D11	X	0.310	0.320	0.320	0.310	
	Y	0.336	0.350	0.318	0.303	
D12	X	0.320	0.330	0.330	0.320	
	Y	0.350	0.365	0.333	0.318	
D21	X	0.310	0.320	0.320	0.310	
	Y	0.303	0.318	0.285	0.271	
D22	X	0.320	0.330	0.330	0.320	
	Y	0.318	0.333	0.300	0.285	

Tolerance of each bin limit = ± 0.02 .

NOTE: Bin categories are established for classification of products. Products may not be available in all categories. Please contact your Broadcom representative for information on current available bins

Figure 2: White Color Bin Limits

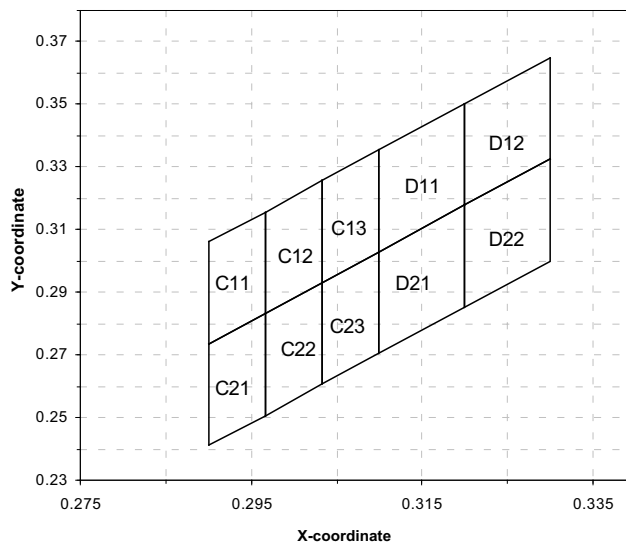

Forward Voltage Bin Limits

Bin ID	Forward Voltage (V)	
	Minimum	Maximum
1	2.90	3.10
2	3.10	3.30
3	3.30	3.50
4	3.50	3.70
5	3.70	3.90

Tolerance : $\pm 0.1V$.

Figure 3: Relative Intensity vs. Wavelength

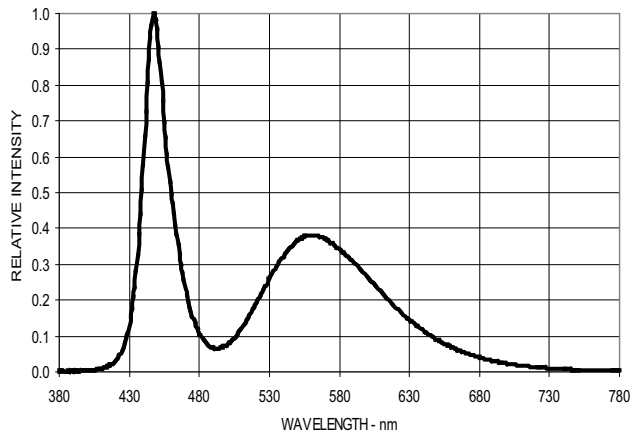

Figure 4: Luminous Intensity vs. Forward Current

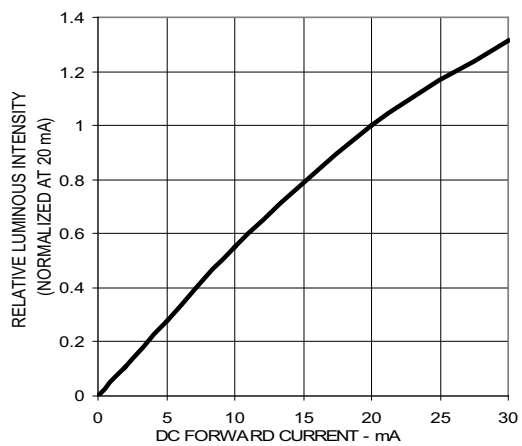

Figure 5: Forward Current vs. Forward Voltage

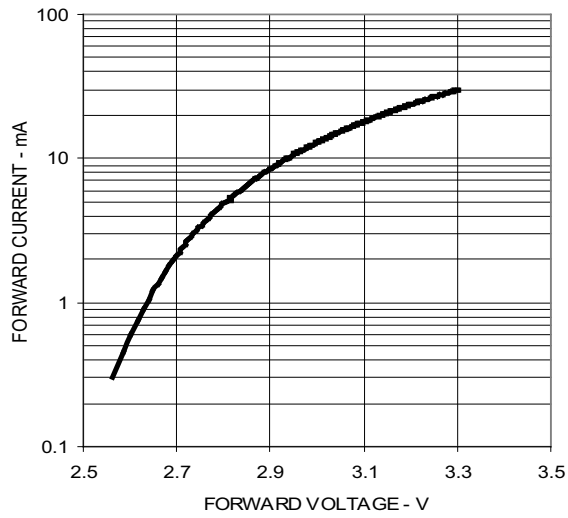

Figure 6: Maximum Forward Current vs. Ambient Temperature

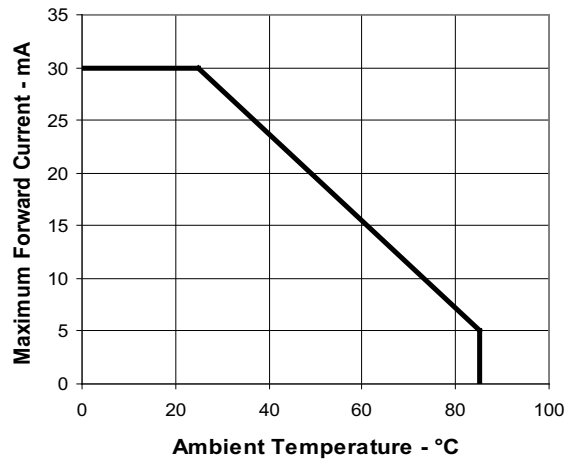

Figure 7: Relative Intensity vs. Angle

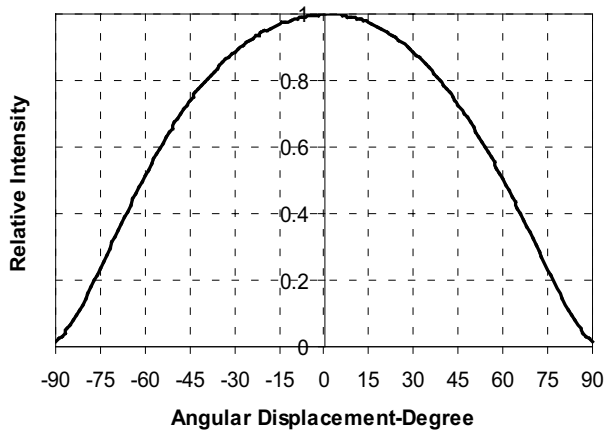

Figure 8: Recommended Soldering Land Pattern

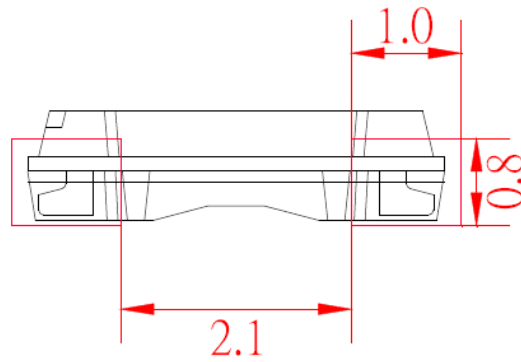

Figure 9: Reel Dimensions

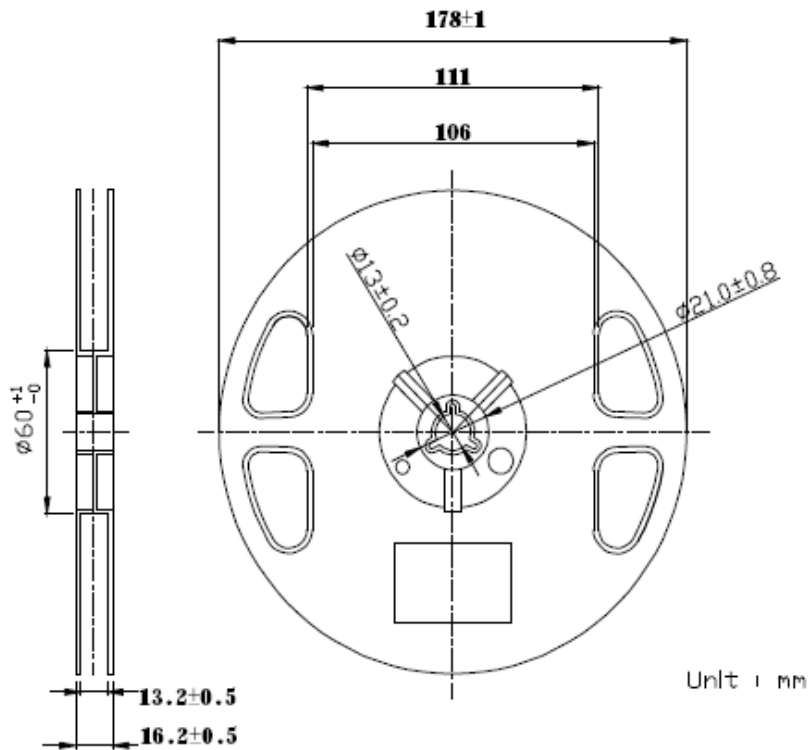

Figure 10: Tape Dimensions (Units: mm)

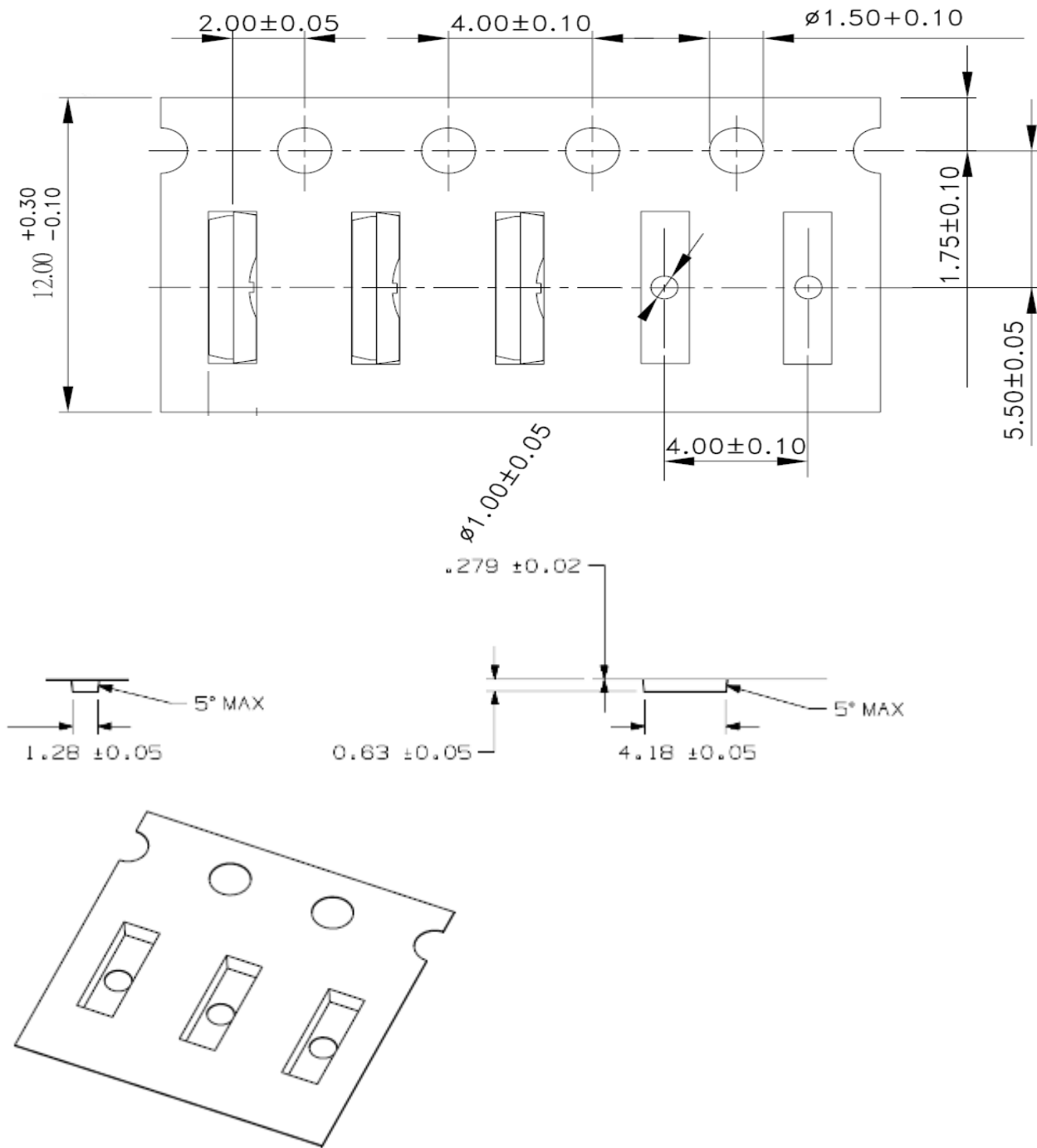
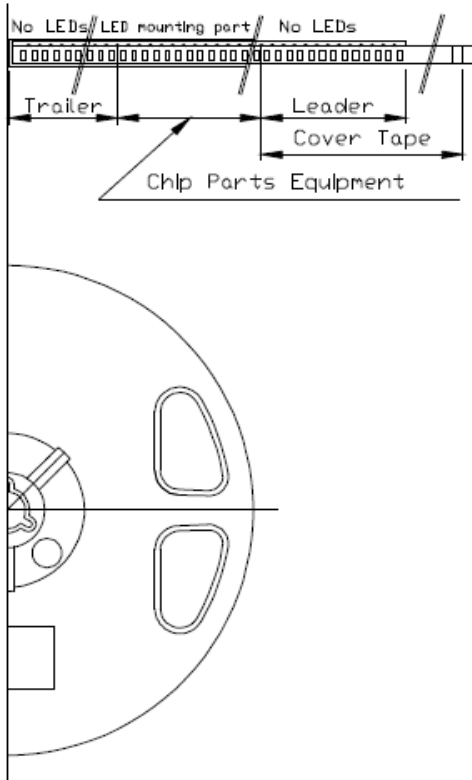

Figure 11: Tape Leader and Trailer Dimensions



Items		Specifications	Remarks
Leader	Cover Tape	Cover tape shall be longer than 400mm without carrier tape	The end of the carrier tape shall be adhered on the cover tape
	Carrier Tape	There shall be more than 40 empties	The orientation of the tape shall be as shown
Trailer		There shall be more than 40 empties	The end of the tape shall be inserted into a slit of the hub

Soldering

- Reflow soldering must not be done more than twice. Observe necessary precautions of handling moisture sensitive device as stated in the following section.
- Do not apply any pressure or force on the LED during reflow and after reflow when the LED is still hot.
- Use reflow soldering to solder the LED. If unavoidable (such as rework), use manual hand soldering strictly controlled to the following conditions:
 - Soldering iron tip temperature = 310°C maximum
 - Soldering duration = 2 seconds maximum
 - Number of cycles = 1 only
 - Power of soldering iron = 50W maximum
- Do not touch the LED package body with the soldering iron except for the soldering terminals because it might cause damage to the LED.
- Confirm beforehand whether the functionality and performance of the LED is affected by hand soldering.

Figure 12: Recommended Lead-Free Reflow Soldering Profile

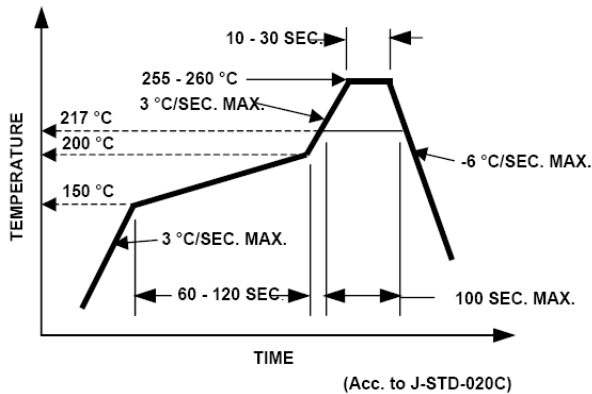

Precautionary Notes

Handling of a Moisture-Sensitive Device

This product has a Moisture Sensitive Level 2a rating per JEDEC J-STD-020. Refer to Broadcom Application Note AN5305, *Handling of Moisture Sensitive Surface Mount Devices*, for additional details and a review of proper handling procedures.

■ Before use

- An unopened moisture barrier bag (MBB) can be stored at < 40°C/90% RH for 12 months. If the actual shelf life has exceeded 12 months and the humidity indicator card (HIC) indicates that baking is not required, it is safe to reflow the LEDs per the original MSL rating.
- Do not open the MBB prior to assembly (for example, for IQC). If unavoidable, the MBB must be properly resealed with fresh desiccant and HIC. The exposed duration must be taken in as floor life.

■ Control after opening the MBB

- Read the HIC immediately upon opening the MBB.
- Keep the LEDs at < 30°C/60% RH at all times, and all high-temperature-related processes, including soldering, curing, or rework, must be completed within 672 hours.

■ Control for unfinished reel

Store unused LEDs in a sealed MBB with desiccant or desiccator at < 5% RH.

■ Control of assembled boards

If the PCB soldered with the LEDs is to be subjected to other high-temperature processes, store the PCB in a sealed MBB with desiccant or desiccator at < 5% RH to ensure that all LEDs have not exceeded their floor life of 672 hours.

■ Baking is required if the following conditions exist:

- The HIC indicator indicates a change in color for 10% and 5% as stated on the HIC.
- The LEDs are exposed to conditions of > 30°C/60% RH at any time.
- The LEDs' floor life exceeded 672 hours.

The recommended baking condition is: 60°C ±5°C for 20 hours.

Baking should only be done once.

Application Precautions

- The drive current of the LED must not exceed the maximum allowable limit across temperature as stated in the data sheet. Constant current driving is recommended to ensure consistent performance.
- Circuit design must cater to the whole range of forward voltage (V_F) of the LEDs to ensure the intended drive current can always be achieved.
- LEDs exhibit slightly different characteristics at different drive currents that might result in larger performance variations (that is, intensity, wavelength, and forward voltage). Set the application current as close as possible to the test current to minimize these variations.
- If the LED is intended to be used along with an LED of another color to achieve color mixing, Broadcom does not guarantee the consistency of the resultant color. Contact a Broadcom sales representative for such applications.
- The LED is not intended for reverse bias. Use other appropriate components for such purposes. When driving the LED in matrix form, ensure that the reverse bias voltage does not exceed the allowable limit of the LED.
- Avoid rapid changes in ambient temperature, especially in high-humidity environments, because they cause condensation on the LED.
- If the LED is intended to be used in harsh or outdoor environments, protect the LED against damages caused by rain water, water, dust, oil, corrosive gases, external mechanical stress, and so on.

Eye Safety Precautions

LEDs may pose optical hazards when in operation. Do not look directly at operating LEDs because it might be harmful to the eyes. For safety reasons, use appropriate shielding or personal protective equipment.

Disclaimer

Broadcom's products are not specifically designed, manufactured, or authorized for sale as parts, components, or assemblies for the planning, construction, maintenance, or direct operation of a nuclear facility or for use in medical devices or applications. The customer is solely responsible, and waives all rights to make claims against Broadcom or its suppliers, for all loss, damage, expense, or liability in connection with such use.

Broadcom, the pulse logo, Connecting everything, Avago Technologies, Avago, and the A logo are among the trademarks of Broadcom and/or its affiliates in the United States, certain other countries and/or the EU.

Copyright © 2018 Broadcom. All Rights Reserved.

The term "Broadcom" refers to Broadcom Limited and/or its subsidiaries. For more information, please visit www.broadcom.com.

Broadcom reserves the right to make changes without further notice to any products or data herein to improve reliability, function, or design. Information furnished by Broadcom is believed to be accurate and reliable. However, Broadcom does not assume any liability arising out of the application or use of this information, nor the application or use of any product or circuit described herein, neither does it convey any license under its patent rights nor the rights of others.

