

High Performance Current Mode PWM Controller

Features

- Power-on Soft Startup
- External Programmable PWM switch Frequency
- Low V_{DD} startup current (<5uA)
- Low operation current
- Extra Low Standby(<75mW)
- Frequency jitter to Minimize EMI
- Leading edge blanking on current sense
- Audio Noise Free Operation
- VDD Under Voltage Lockout (UVLO)
- VDD Over Voltage Protection (OVP)
- Cycle-by-cycle Over Current Protection (OCP)
- Overload Protection (OLP)
- Over Temperature Protection (OTP)

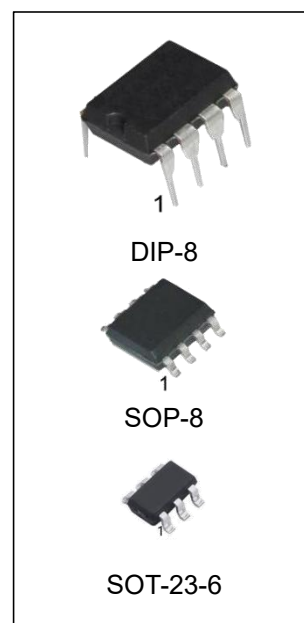

Ordering Information

DEVICE	Package Type	MARKING	Packing	Packing Qty
HX2263PG	DIP-8	HX2263,2263	TUBE	2000pcs/box
HX2263DRG	SOP-8	HX2263,2263	REEL	2500pcs/reel
HX2263DRG4	SOP-8	HX2263,2263	REEL	4000pcs/reel
HX2263DBVRG	SOT-23-6	2263,63XXX	REEL	3000pcs/reel

Note: The XXX in the marker indicates the lot number.

Description

HX2263 is a highly integrated current mode PWM controller optimized for high performance, low standby power and cost effective offline flyback converter applications.

At full loading, the IC operates in fixed frequency mode. When the loading goes low, it operates in Green Mode for high power conversion efficiency. At no load or light load condition, HX2263 operates in Burst Mode to minimize switching loss. Less than 75mW standby power consumption and very high conversion efficiency is thus achieved.

HX2263 offers comprehensive protection coverage with auto-recovery including over load protection (OLP), Cycle-by-Cycle current limiting (OCP), VDD under voltage lockout (UVLO), over temperature protection (OTP), and over voltage protection (OVP). Excellent EMI performance is achieved with internal frequency jitter technique.

The tone energy at below 22KHz is minimized in the design and audio noise is eliminated during operation.

HX2263 is offered in SOT-23-6/SOP-8/DIP-8 package.

Applications

Offline AC/DC flyback converter for

- AC/DC Adapter
- Set-Top Box Power Supplies
- Auxiliary Power Supply
- Open-frame SMPS

Pin Configuration

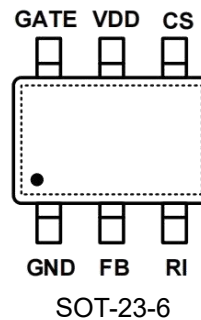
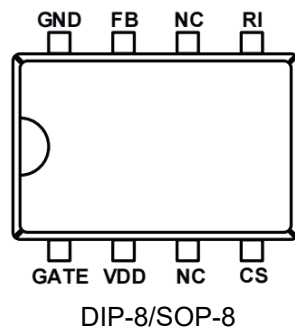

Pin Descriptions

Pin		Name	Description
SOT-23-6	SOP-8/DIP-8		
1	8	GND	Ground
2	7	FB	Feedback input pin
3	5	RI	This pin is to program the switching frequency. By connecting a resistor to ground to set the switching frequency.
4	4	CS	Current sense input, connected through a resistor to GND to set the primary side peak current
5	2	VDD	IC DC power supply input
6	1	GATE	Totem-pole gate driver output for power MOSFET
-	3,6	NC	Not connect

Block Diagram

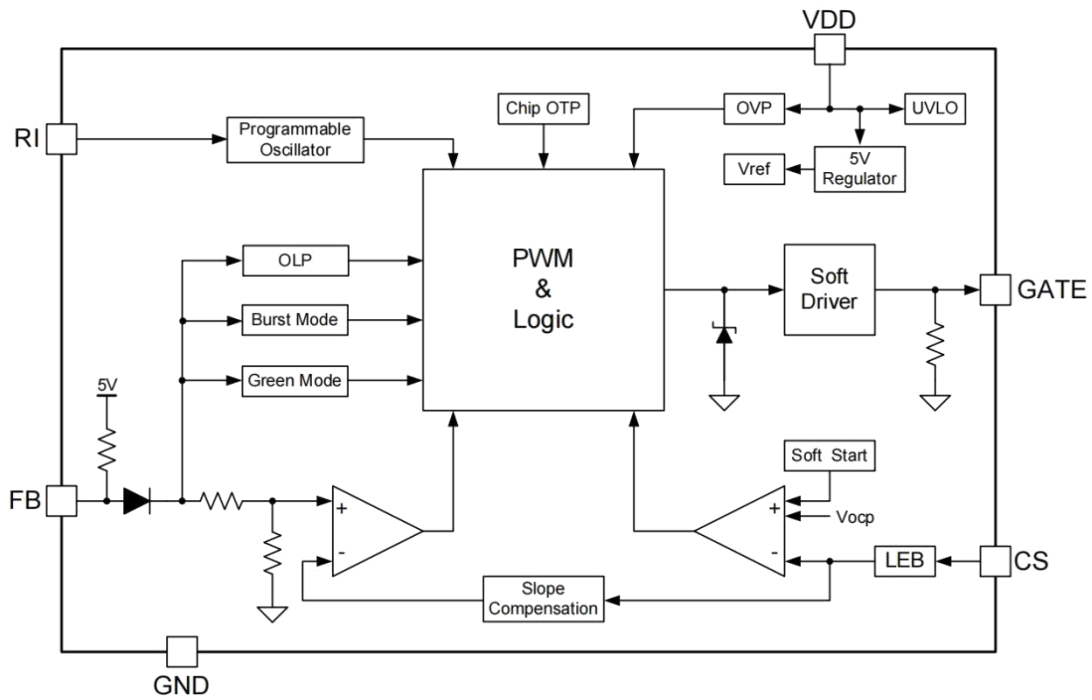

Typical Application

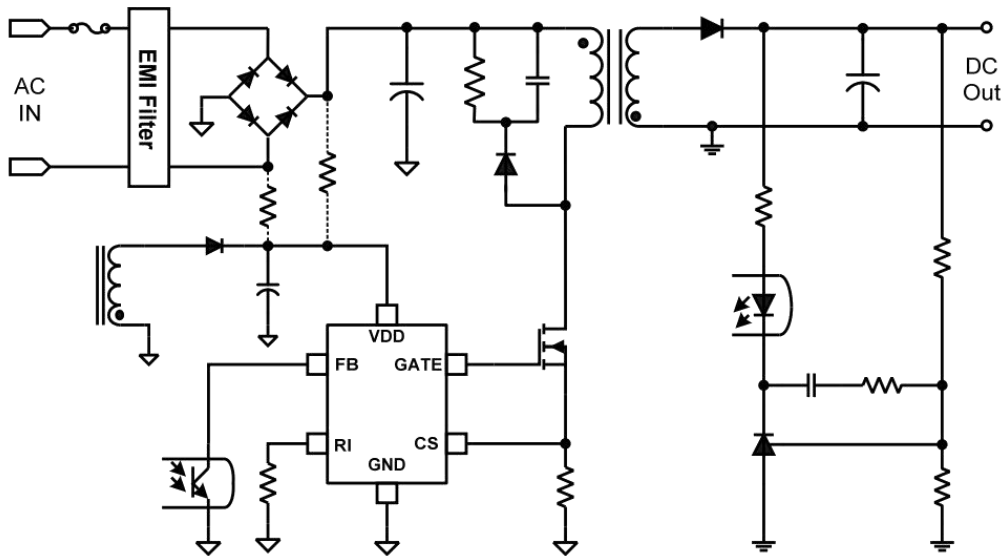

Absolute Maximum Ratings

Symbol	Parameter	Min.	Max.	Unit
V _{DD}	DC Supply Voltage		38	V
I _{DD}	VDD DC Clamp Current		10	mA
V _{FB}	FB Input Voltage	-0.3	5	V
V _{CS}	CS Input Voltage	-0.3	5	V
V _{RI}	RI Input Voltage	-0.3	5	V
R _{JA}	SOT23-6 Thermal Resistance (Junction-to-Air)		200	°C/W
	SOP-8 Thermal Resistance (Junction-to-Air)		150	°C/W
	DIP-8 Thermal Resistance (Junction-to-Air)		75	°C/W
T _J	Operating Junction Temperature	-20	150	°C
T _{STG}	Storage Temperature Range	-55	160	°C
T _L	Lead Temperature (Wave Soldering or IR,10Seconds)		260	°C
ESD	Human Body Model,JEDEC:JESD22-A114		2.5	KV
	Machine Model, JEDEC:JESD22- A115		250	V

Stresses beyond those listed under “absolute maximum ratings” may cause permanent damage to the device. These are stress ratings only, functional operation of the device at these or any other conditions beyond those indicated under “recommended operating conditions” is not implied. Exposure to absolute maximum-rated conditions for extended period may affect device’s reliability

Recommended Operating Conditions

Symbol	Parameter	Min.	Max.	Unit
V _{DD}	DC Supply Voltage	10	34	V
T _A	Operating Ambient Temperature	-20	85	°C
C _{VDD}	VDD Capacitor	4.7	10	uF
R _{ST_AC}	Start-up resistor Value (AC Side, Half Wave)	400	2000	KΩ
R _{ST_DC}	Start-up resistor Value (DC Side, Filter Capacitor)	2000	4000	KΩ

Electrical Characteristics

($T_A = 25^\circ\text{C}$, $V_{DD}=18\text{V}$, $R_I=100\text{K}\Omega$, unless otherwise noted)

Symbol	Parameter	Conditions	Min.	Typ.	Max.	Unit
Supply Voltage (VDD)						
I_{DD_ST}	Startup Current	$V_{DD}=V_{DD_ON}-1\text{V}$		1.0	3.0	μA
I_{DD_OP}	Operation Current	$V_{FB}=3\text{V}$		2.5	3.0	mA
I_{DD_Burst}	Burst Current	$V_{CS}=0\text{V}, V_{FB}=0.5\text{V}$		0.45	0.60	mA
V_{DD_ON}	Threshold Voltage to Startup	VDD Rising	16.0	17.0	18.0	V
V_{DD_OFF}	Threshold Voltage to Stop Switching in Normal Mode	VDD Falling	7.0	8.0	9.0	V
$V_{Pull-up}$	Pull-up PMOS active			10		V
V_{DD_OVP}	Over voltage protection voltage		34.0	35.0	36.0	V
V_{DD_Clamp}		$I_{DD}=10\text{mA}$		38.0		V
Feedback Input Section(FB Pin)						
V_{FB_Open}	FB Open Loop Voltage			4.7		V
A_v	PWM input gain $\Delta V_{FB}/\Delta V_{CS}$			1.71		V/V
D_{MAX}	Max duty cycle	$V_{FB}=3\text{V}, V_{CS}=0.3\text{V}$	77	80	83	%
V_{Ref_Green}	The threshold enter green mode			1.95		V
$V_{Ref_Burst_H}$	The threshold exit Burst mode			1.2		V
$V_{Ref_Burst_L}$	The threshold enter Burst mode			1.1		V
I_{FB_Short}	FB pin short circuit current	Short FB pin to GND		0.3		mA
V_{TH_PL}	Power Limiting FB Threshold Voltage			3.4		V
T_{D_PL}	Power limiting Debounce Time			60		mS
Z_{FB_IN}	Input Impedance			20		$\text{K}\Omega$
Current Sense Input(CS Pin)						
T_{SS}	Soft start time			5		ms
T_{LEB}	Leading edge blanking time			300		ns
T_{D_OC}	Over Current Detection and Control Delay			90		ns
V_{TH_OC}	Current Limiting Threshold Voltage with zero duty cycle			0.80		V
V_{OCP_Clamp}	CS voltage clamber			1.05		V
Oscillator						
F_{OSC}	Normal Oscillation Frequency	$R_I=100\text{K}\Omega$	60	65	70	KHz
F_{JR}	Frequency jitter range			+/-4		%
F_{Jitter}	jitter frequency			25		Hz
F_{DT}	Frequency Variation vs. Temperature Deviation			5		%
F_{DV}	Frequency Variation vs. V_{DD} Deviation			1		%
F_{Burst}	Burst Mode Switch Frequency			22		KHz

R_{I_range}	Operation RI range		50	100	150	K Ω
V_{RI_open}	RI open load voltage			1.0		V
GATE Driver						
V_{Gate_L}	Gate low level	$V_{DD}=14V, I_o=5mA$			1	V
V_{Gate_H}	Gate high level	$V_{DD}=14V, I_o=20mA$	6			V
V_{Gate_Clamp}	Gate clamp voltage			13.5		V
T_R	Gate rising time	$C_L=1000pF$		260		nS
T_F	Gate falling time	$C_L=1000pF$		70		nS
In-chip OTP						
T_{OTP_EN}	OTP enter			150		$^{\circ}C$
T_{OTP_EX}	OTP exit			120		$^{\circ}C$

Performance Characteristics

($T_A = 25^{\circ}C, V_{DD}=18V, R_I=100K\Omega$, unless otherwise noted)

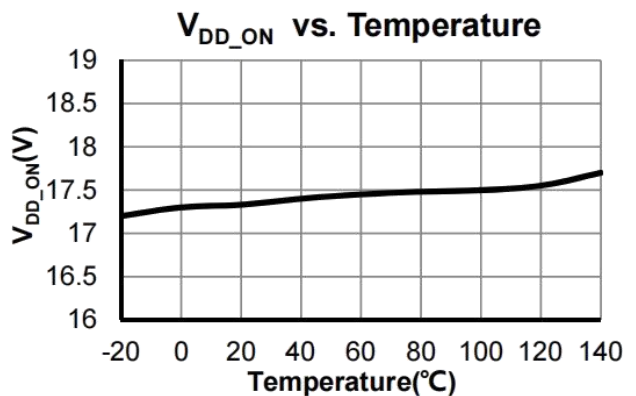
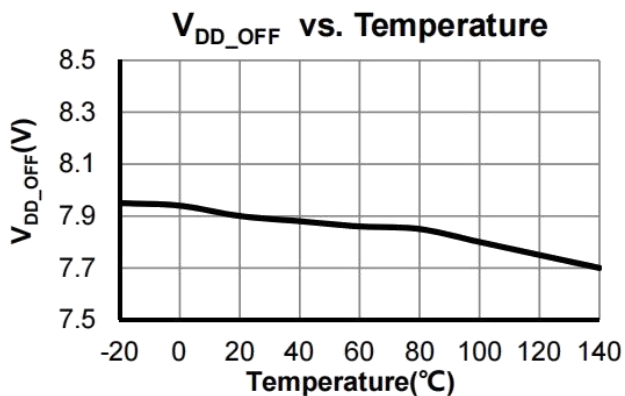
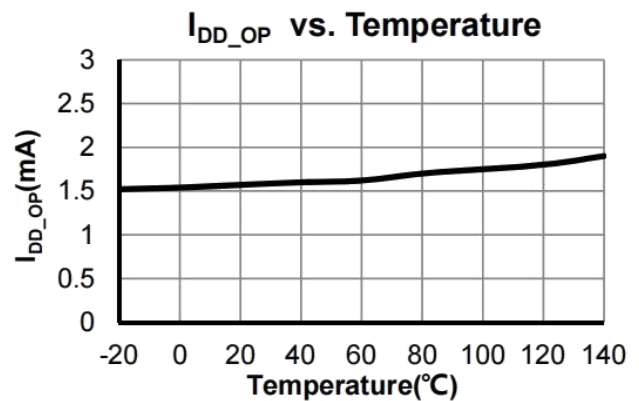
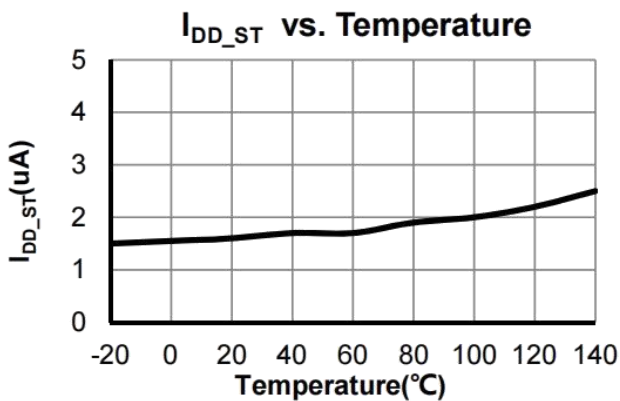

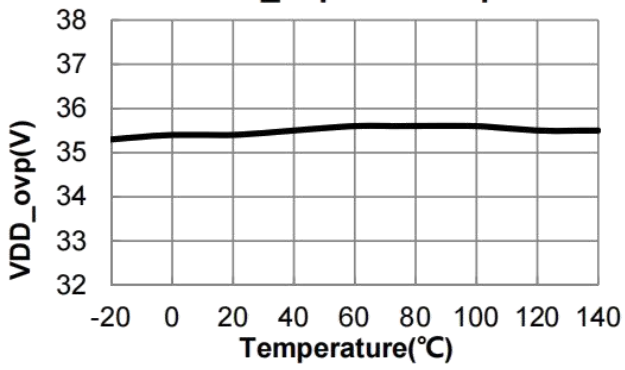
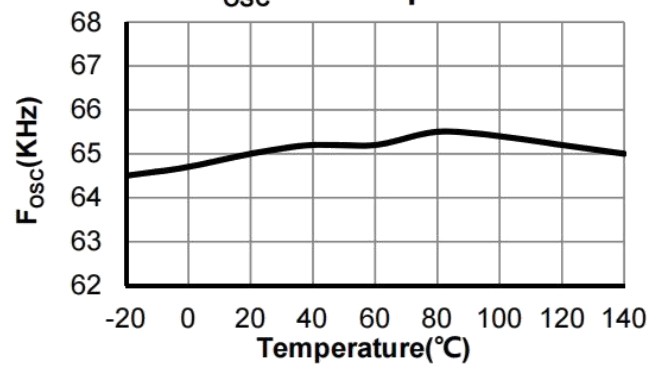
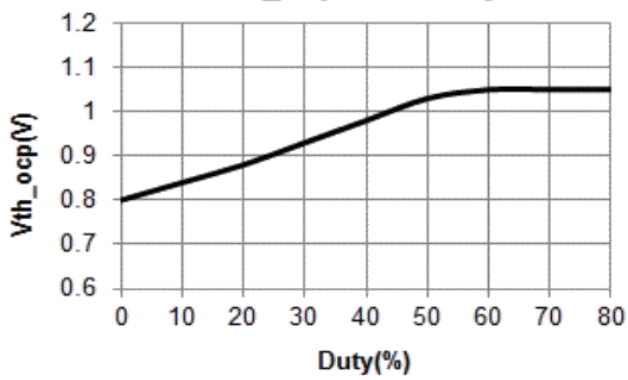
VDD_ovp vs. Temperature

F_{OSC} vs. Temperature

Vth_ocp vs. Duty

Functional Description

HX2263 is a highly integrated current mode PWM Power Controller optimized for high performance, extra low standby power consumption and cost effective offline flyback converter applications. The “Burst Mode” control greatly reduces the standby power consumption and helps the design easier to meet the international power conservation requirements.

Startup Current and Start up Control

Startup current of HX2263 is designed to be very low so that VDD could be charged up above V_{DD_ON} and device starts up quickly. A large value startup resistor can therefore be used to minimize the power loss yet achieve a reliable startup in application.

Operating Current

The Operating current of HX2263 is low at 2.5mA (typical). Good efficiency is achieved with HX2263 low operation current together with the ‘Burst Mode’ control features.

Soft Start

HX2263 features an internal 5ms (typical) soft start to soften the electrical stress occurring in the power supply during startup. It is activated during the power on sequence. As soon as VDD reaches V_{DD_ON} , the CS peak voltage is gradually increased from 0.05V to the maximum level. Every restart up is followed by a soft start.

Frequency jitter for EMI improvement

The frequency jitter is implemented in HX2263. The oscillation frequency is modulated so that the tone energy is spread out. The spread spectrum minimizes the conduction band EMI and therefore eases the system design.

Internal Bias and OSC Operation

A resistor connected between RI pin and GND pin sets that the internal constant current source charge or discharge to the internal fixed capacitor. The charge time and discharge time decides the internal clock frequency. Increasing the resistance will reduce the input current and the switching frequency. The relationship between RI and PWM switching frequency follows the below equation within the RI allowed range.

$$F_{osc} = \frac{6500}{BI(K\Omega)} (KHZ)$$

For example, a 100K Ω resistor RI could generate 10uA constant current and 65KHz PWM switching frequency. The suggested operating frequency range of HX2263 is from 50 KHz to 150 KHz.

Multi-mode Operation for High Efficiency

HX2263 is a multi-mode controller. The controller changes the mode of operation according to the FB pin voltage. At the normal operating condition, the IC operates in traditional fix frequency 65KHz (RI=100K) PWM mode. As the output load current is decreased, the IC enter into Green Mode smoothly from the PWM mode. In this mode, the switching frequency will start to linearly decrease from 65KHz (RI=100K) to 22KHz. So the switching loss is minimized and the high conversion efficiency can be achieved. At light load or no load condition, most of the power dissipation in a switching mode power supply is from switching loss of the MOSFET, the core loss of the transformer and the loss of the snubber circuit. The magnitude of power loss is in proportion to the switching frequency. Lower switching frequency leads to the reduction on the power loss and thus conserves the energy. The switching frequency is internally adjusted at no load or light load condition. The

switch frequency reduces at light/no load condition to improve the conversion efficiency.

At light load or no load condition, the FB input drops below $V_{\text{Ref_Burst_L}}$ and device enters Burst Mode control. The Gate drive output switches when FB input rises back to $V_{\text{Ref_Burst_H}}$. Otherwise the gate drive remains at off state to minimize the switching loss and reduces the standby power consumption to the greatest extent.

Current Sensing and Leading Edge Blanking

Cycle-by-Cycle current limiting is offered in HX2263 current mode PWM control. The switch current is detected by a sense resistor into the CS pin. An internal leading edge blanking circuit chops off the sensed voltage spike at initial power MOSFET on state due to snubber diode reverse recovery and surge gate current of power MOSFET. The current limiting comparator is disabled and cannot turn off the power MOSFET during the blanking period. The PWM duty cycle is determined by the current sense input voltage and the FB input voltage.

Internal Synchronized Slope Compensation

Built-in slope compensation circuit adds voltage ramp into the current sense input voltage for PWM generation. This greatly improves the close loop stability at CCM and prevents the sub-harmonic oscillation and thus reduces the output ripple voltage.

Protection Controls

Good power supply system reliability is achieved with auto-recovery protection features including Cycle-by-Cycle current limiting (OCP), Under Voltage Lockout on VDD (UVLO), Over Temperature Protection (OTP), VDD Over Voltage Protection (OVP). The OCP is line voltage compensated to achieve constant output power limit over the universal input voltage range. At overload condition when FB input voltage exceeds power limit threshold value for more than $T_{\text{D_PL}}$, control circuit reacts to shut down the converter. It restarts when VDD voltage drops below UVLO limit.

Physical Dimensions

DIP-8

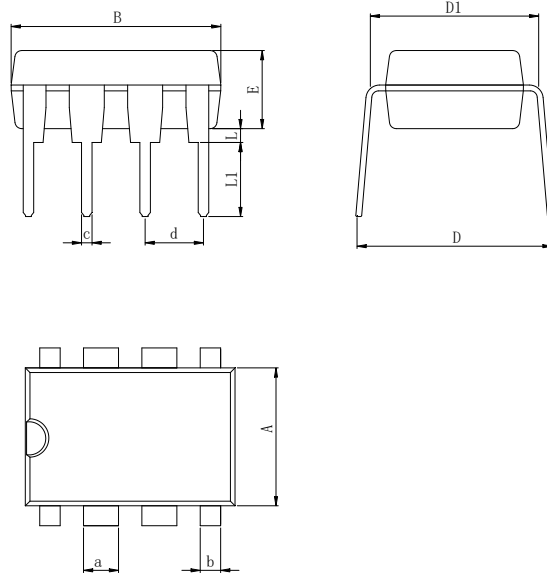

Dimensions In Millimeters(DIP-8)

Symbol:	A	B	D	D1	E	L	L1	a	b	c	d
Min:	6.10	9.00	8.10	7.42	3.10	0.50	3.00	1.50	0.85	0.40	2.54 BSC
Max:	6.68	9.50	10.9	7.82	3.55	0.70	3.60	1.55	0.90	0.50	

SOP-8 (150mil)

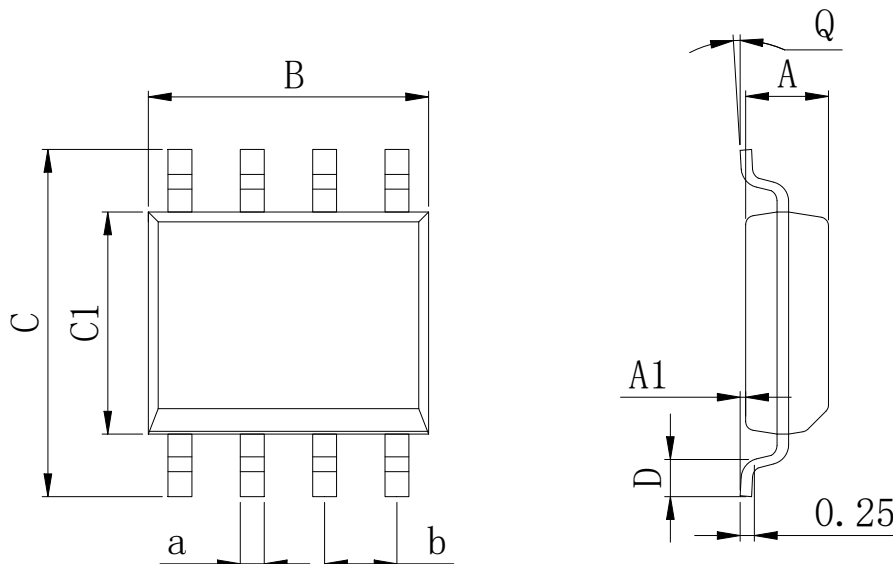

Dimensions In Millimeters(SOP-8)

Symbol:	A	A1	B	C	C1	D	Q	a	b
Min:	1.35	0.05	4.90	5.80	3.80	0.40	0°	0.35	1.27 BSC
Max:	1.55	0.20	5.10	6.20	4.00	0.80	8°	0.45	

Physical Dimensions

SOT-23-6

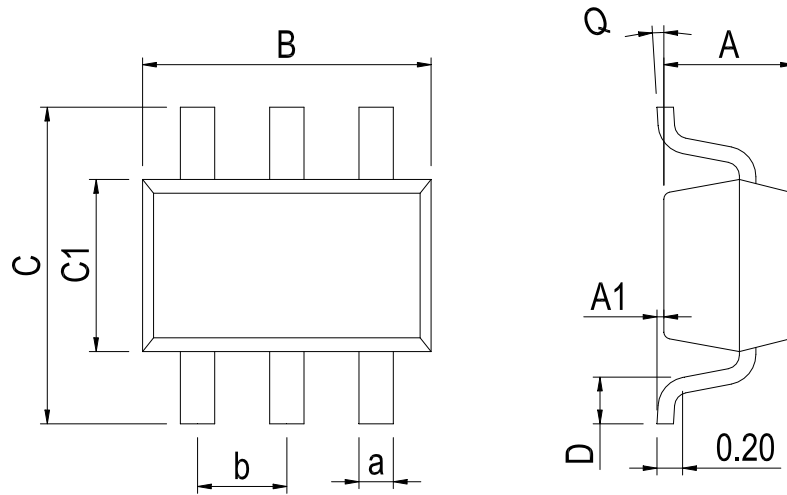

Dimensions In Millimeters(SOT-23-6)

Symbol:	A	A1	B	C	C1	D	Q	a	b
Min:	1.00	0.00	2.82	2.65	1.50	0.30	0°	0.30	0.95 BSC
Max:	1.15	0.15	3.02	2.95	1.70	0.60	8°	0.50	

Revision History

REVISION NUMBER	DATE	REVISION	PAGE
V1.0	2019-11	New	1-13
V1.1	2024-10	Document Reformatting, Add a model marking name	1-13
V1.2	2024-11	Update Lead Temperature	4

IMPORTANT STATEMENT:

hanschip Semiconductor reserves the right to change products and services offered without prior notice. Customers should obtain the latest relevant information before placing orders and verify that such information is current and complete. hanschip Semiconductor assumes no responsibility or liability for altered documents.

Customers are responsible for complying with safety standards and implementing safety measures when using hanschip Semiconductor products in system design and end-product manufacturing. You assume full responsibility for: selecting the appropriate hanschip Semiconductor products for your application; designing, validating, and testing your application; and ensuring that your application complies with applicable standards and all other safety, security, or other requirements. This is to prevent potential risks that may lead to personal injury or property damage.

hanschip Semiconductor products are not approved for use in life support, military, aerospace, or other high-risk applications. hanschip products are neither intended nor warranted for use in such systems or equipment. Any failure or malfunction may lead to personal injury or severe property damage. Such applications are deemed "Unsafe Use." Unsafe Use includes, but is not limited to: surgical and medical equipment, nuclear energy control equipment, aircraft or spacecraft instruments, control or operation of vehicle power, braking, or safety systems, traffic signal instruments, all types of safety devices, and any other applications intended to support or sustain life. hanschip Semiconductor shall not be liable for consequences resulting from Unsafe Use in these fields. Users must independently evaluate and assume all risks. Any issues, liabilities, or losses arising from the use of products beyond their approved applications shall be solely borne by the user. Users may not claim any compensation from hanschip Semiconductor based on these terms. If any third party claims against hanschip Semiconductor due to such Unsafe Use, the user shall compensate hanschip Semiconductor for all resulting damages and liabilities.

hanschip Semiconductor provides technical and reliability data (including datasheets), design resources (including reference designs), application or other design advice, web tools, safety information, and other resources for its semiconductor products. However, no guarantee is made that these resources are free from defects, and no express or implied warranties are provided. The use of testing and other quality control techniques is limited to hanschip Semiconductor's quality assurance scope. Not all parameters of each device are tested.

hanschip Semiconductor's documentation authorizes you to use these resources only for developing applications related to the products described herein. You are not granted rights to any other intellectual property of hanschip Semiconductor or any third party. Any other reproduction or display of these resources is strictly prohibited. You shall fully indemnify hanschip Semiconductor and its agents against any claims, damages, costs, losses, and liabilities arising from your use of these resources. hanschip Semiconductor shall not be held responsible.