

KBP303 thru KBP309

3 A single-phase Bridge Rectifier
 Rectifier Reverse voltage 50 to 1000v

KBP

Features

- This series is UL listed under the Recognized Component Index, file number E484648
- **Ideal for printed circuit board mounting**
- The plastic material used carries Underwriters Laboratory flammability recognition 94V-0
- Built-in printed circuit board stand-offs
- High case dielectric strength
- High temperature soldering guaranteed 265°C / 10 seconds at 5 lbs (2.3kg) tension

Mechanical Data

Case: Reliable low cost construction utilizing molded plastic technique

Terminals: Plated leads solderable per MIL-STD-202, Method 208

Mounting position: Any

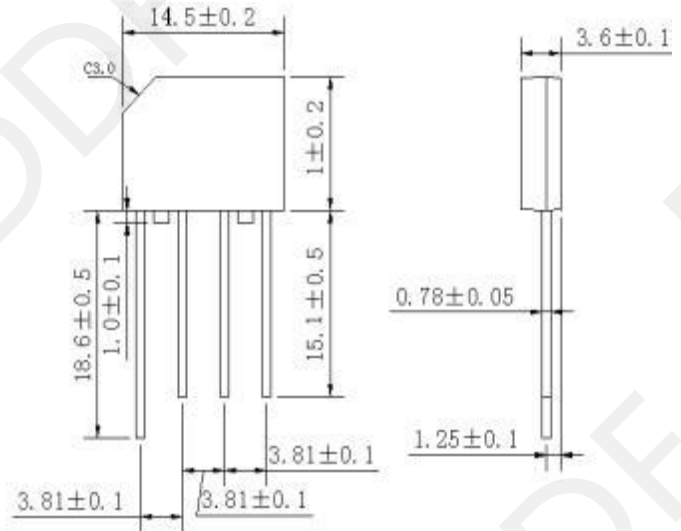

Dimensions in millimeters (1mm = 0.0394")

Maximum Ratings & Thermal Characteristics

Rating at 25°C ambient temperature unless otherwise specified, Resistive or Inductive load, 60 Hz.
 For Capacitive load derate current by 20%.

Parameter	Symbol		KBP303	KBP305	KBP307	KBP309		unit
Maximum repetitive peak reverse voltage	VRRM		300	500	700	900		V
Maximum RMS bridge input voltage	VRMS		140	280	420	560		V
Maximum DC blocking voltage	VDC		300	500	700	900		V
Maximum average forward rectified output current at TA=40°C	IF(AV)		3.0					A
Peak forward surge current single sine-wave superimposed on rated load (JE DEC Method)	IFSM		60					A
operating junction and storage temperature range	TJ, TSTG		-55 to + 150					°C

Electrical Characteristics

Rating at 25°C ambient temperature unless otherwise specified. Resistive or Inductive load, 60Hz.
 For Capacitive load derate by 20 %.

Parameter	Symbol		KBP303	KBP305	KBP307	KBP309		Unit
Maximum instantaneous forward voltage drop per leg at 3.0 A	VF		1.1					V
Maximum DC reverse current at rated TA = 25°C DC blocking voltage per element TA = 125°C	IR		10 500					UA

Notes: (1) Thermal resistance from Junction to Ambient on P.C. board mounting.
 (2) Measured at 2.0MHz and applied reverse voltage of 4.0 volts.

Rating and characteristic curves(TA=25 c unless otherwise noted).

KBP3005 thru KBP310

Fig. 1 Derating Curve for Output Rectified Current

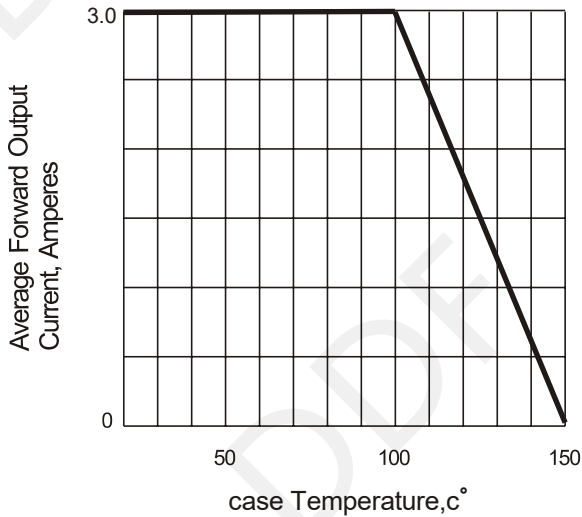

Fig. 2 Maximum Non-repetitive Peak Forward Surge Current

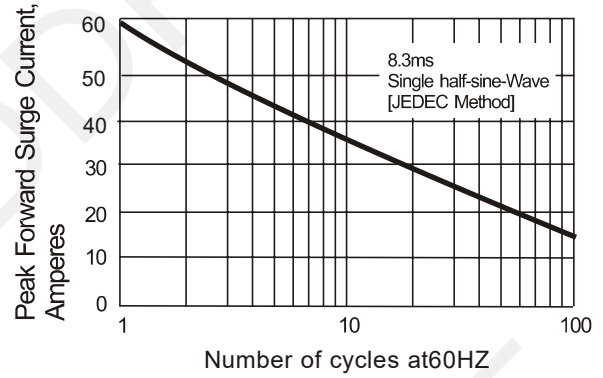

Fig. 3 Typical Instantaneous Forward Characteristics

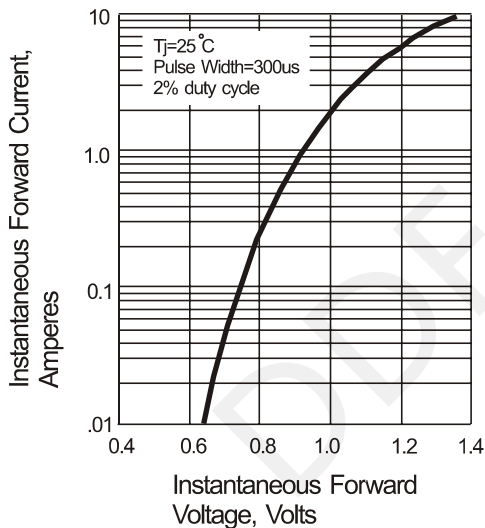

Fig. 4 Typical Reverse Characteristics

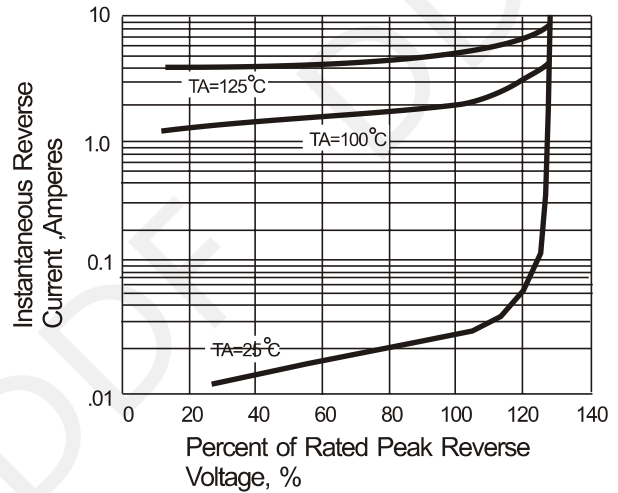

Fig.5 Typical Junction capacitance

