



# 圓達實業股份有限公司



NP□□-□□□V 產品規格書

文件編號：E-V-AD16 (auto)  
 版次：A  
 發行日期：2021/7/27  
 修訂日期：-  
 擬案：P a g g y  
 審查：  
 核准：

文 件 發 行 受 文 單 位													共 4 份	
單 位 份	董 事 長 室	生 產	塑 膠	業 務	工 程	品 保	管 理	研 發	資 訊	財 務	沖 壓	惟 達 資 料 室	發行單位	發行管制章
													研 發	
				1		1		1				1		

文 件 修 訂 變 更 履 歷 欄			
版 次	修 訂 原 因 · 內 容 摘 要	修 訂 頁 次	修 訂 日 期
A	技通 21095 發行	—	—



一、產品型態：

本規格書是描述"琴鍵型指撥式開關"，一般之機械特性與電氣特性, 而該指撥式琴鍵開關主要是用來作為訊號開關之電子裝置。

1. 使用之溫度範圍：-40°C ~ +85°C
2. 儲存之溫度範圍：-40°C ~ +85°C

二、額定電流：

1. 當開關之設定已固定不再作任何切換，而使電流常處於一平穩的通電狀態時，則額定電流為：100 mA, 50 VDC。
2. 當開關的設定不固定常需作任意切換，而使電流常處於一脈衝狀態時，則額定電流為：25 mA, 24 VDC。

三、操作類型：指撥轉動。

四、測試項目：

特性	項次	測試種類	測 試 條 件	測 試 要 求
電 氣	1	目視檢查	在未施加任何外力及試驗前, 以目視方式檢測	產品的外觀不能有影響產品功能之不良缺點
	2	接觸阻抗	①測定通路時, 在開關兩極端測量端子間的接觸阻抗值。 ②測定時以 1KHZ 規格的微電流阻抗計測量之	1. 接觸阻抗的初值不得高於 100mΩ 2. 各種測試後, 其接觸阻抗值不得高於 200 mΩ.
	3	絕緣阻抗	直流電壓 500V, 1 分鐘±5 秒	絕緣阻抗不得低於 100MΩ
特	4	耐電壓	以 500V 的交流電(50Hz 或 60Hz 近似正弦波電壓), 電壓施於兩相鄰端子與底座間, 並保持 1 分鐘之加壓狀態後, 檢查是否能耐該值	成品不得有故障, 跳火及絕緣體破壞等不良現象
性	5	靜電容量	在頻率 1MHZ±10KHZ 下, 測量電容含值	該電容值需 5pF 以下

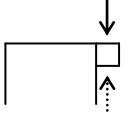

機	6	作動力	如圖所示,各箭頭方向即為測定推鈕操作方向之力量 ON→OFF OFF→ON 	800gf MAX.									
	7	操作部強	以 1kgf 的靜態荷重施於操作方向測定,操作時間 60 秒	操作部不得變形及機械的功能發生故障或損壞									
械	8	抗焊錫熱	①焊溫： <table border="1"> <tr> <td>產品</td> <td>NPI□</td> <td>NPM□</td> </tr> <tr> <td>溫度</td> <td>260±5°C</td> <td>見 IR</td> </tr> <tr> <td>時間</td> <td>5±1 秒</td> <td>溫度曲線圖</td> </tr> </table>	產品	NPI□	NPM□	溫度	260±5°C	見 IR	時間	5±1 秒	溫度曲線圖	受測後的成品仍須符合前述 1, 2, 3, 4, 6 測試項規格的要求。
			產品	NPI□	NPM□								
溫度	260±5°C	見 IR											
時間	5±1 秒	溫度曲線圖											
②焊錫操作之次數,最多 2 次 (PCB 厚度為 1.6mm)													
特	9	振動測試	請依照 MIL-STD-202F, 203B 所規定之方法做測試 ①頻率:10-55-10Hz 的頻率循環測試,週期 1 分鐘 ②振動方向:以 X, Y, Z 三軸向,包含推鈕操作之方向 ③測試時間:每一方向 2 小時 ④全振幅 1.5 mm	受測後之成品仍需符合前述 1, 2, 3, 4, 6, 測試項規格的要求									
	10	衝擊試驗	請依照MIL-STD-202F, 213B 條件 A 所規定之方法做測試 ①加速度：50G ②測定時間：11±1 毫秒 ③受測方向:以成品全周,三軸六個方向作測試 ④受測次數:每一方向三次	受測後之成品仍需符合前述 1, 2, 3, 4, 6, 測試項規格的要求									
性	11	沾錫性	①NP-V 焊溫：245±3°C 焊錫規格：M705E JIS Z 3282 A 級 (錫 96.5%，銀 3%，銅 0.5%) ②助焊劑：5-10 秒 ③浸錫時間：5±1 秒	鍍金/錫面不能有拒焊現象 沾錫面積占總面積 75%以上									



耐 久 性	12	壽命測試	測試時需依照下列所設定情況 ①施以 10mA, 5 V 之直流電 ②作動速度：15~20 回/min ③受測次數：2000 回	(1)受測後之成品仍需符合前述 1, 3, 4 測試項規格之要求 (2)經過測試後之接觸阻抗值不 得高於 200mΩ
	耐 候 性	13	耐寒性	請依照下列所設定的條件測試 後.並於常溫常濕中放置 1 小時 後測定 ①受測溫度：-40±3°C ②受測時間：96 小時
14		耐熱性	請依照下列所設定的條件測試 後.並於常溫常濕中放置 1 小時 後測定 ①受測溫度：85°C±2°C ②受測時間：96 小時	(1)受測後之成品仍需符合前述 3, 4, 6 測試項規格之要求 (2)經過測試後之接觸阻抗值不 得高於 200mΩ
15		耐濕性	請依照下列所設定的條件測試 後.並於常溫常濕中放置 1 小時 後測定 ①受測溫度：85±2°C ②相對濕度：90-95% ③受測時間：96 小時	(1)受測後之成品仍需符合前述 1, 4, 6 測試項規格之要求 (2)經過測試後之接觸阻抗值不 得高於 200mΩ (3)受測後之絕緣阻抗不得低於 100MΩ



■ NP□□-□□□-V 系列

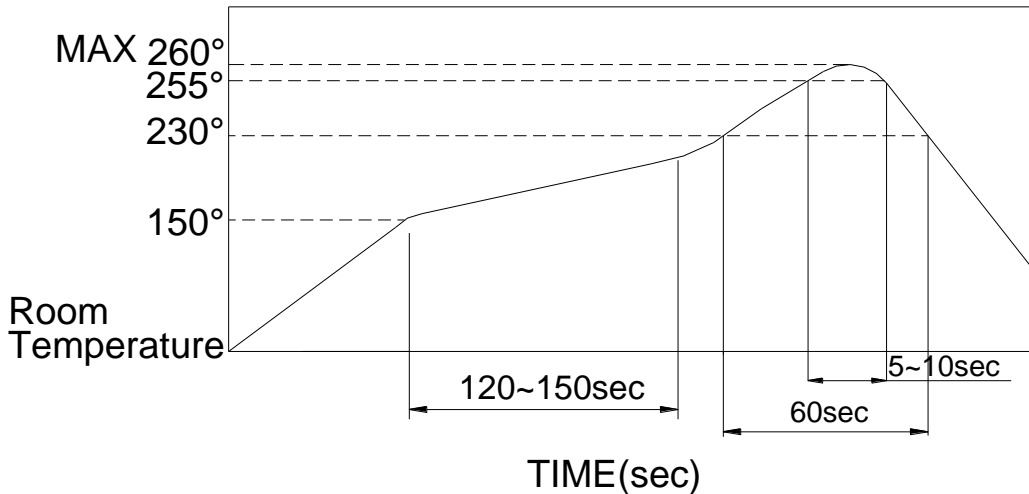

■上述提到的情況是 PCB 上銅鉚之溫度。

有一些情形是這 PCB 的溫度和開關表面之溫度會有很大的不同，這和 PCB 材質，大小，厚度等有很大的關係，因此要小心不要讓表面的溫度超過 260 °C

■手工焊錫

焊錫溫度	350°C 以下
連續焊錫時間	5 秒以下

■處理時注意事項

1. 在 PCB 面上之助焊劑，不要黏到開關本身
2. 本產品請於 OFF 位置進行過錫爐、補焊等高溫作業，若不慎置於 ON 位置進行作業時，可能造成操作力下降及接觸阻值升高等現象發生。
3. 若使用 FLUX 為發泡式，則要管制其發泡面高度，不可超過已放置 S.W 的 PCB 表面，如果 FLUX 發泡面超過 PCB 表面，可能會侵入 S.W 內部，會變成導通不良原因
4. 請勿清洗開關本身

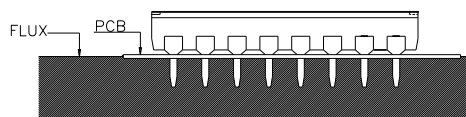



■儲存條件的注意事項：

當物品被儲存於以下的情形與條件它可能會影響產品功能變差及吃錫性等..

應避免儲存於下列情形

1. 在有腐蝕性氣體的地方
2. 陽光直接照射的地方

\*以包裝的狀態儲存以避免重力承載

\*請儘快使用我們建議3個月之內最多6個月內使用完畢

\*打開包裝後,要將未使用完剩餘產品存放在適當的防潮&密閉環境中



# NP□□-□□V SPECIFICATION

FILE No.	: E-V-AD16 (automation)
REV.	: A
Page	: 1 / 5

## 1. Style:

This specification describes "PUSH LEVER SWITCHES", mainly used as signal switch of electric devices, with the general requirements of mechanical and electrical characteristics.

1.1 Operating Temperature Range : -40°C ~ +85°C

1.2 Storage Temperature Range : -40°C ~ +85°C

2. Contact Rating : 100mA, 50VDC

Switching Rating : 25mA, 24VDC

3. Type of Actuation: Actuated by Rotating

4. Test Sequence:

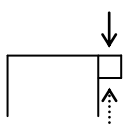
	ITEM	DESCRIPTION	TEST CONDITIONS	REQUIREMENTS
ELECTRIC PERFORMANCE	1.	Visual Examination	By visual examination check without any out pressure & testing.	There shall be no defects that affect the serviceability of the product.
	2.	Contact Resistance	1) To be measured between the two terminals associated with each switch pole. 2) Measurements shall be made with a 1 kHz shall current contact resistance meter.	1) 100mΩ max. (initial) 2) After various kinds of test, it contacts impedance and can not be worth being higher than 200 mΩ Max
	3.	Insulation Resistance	500V DC, 1 minute ± 5 sec.	100MΩ min.
	4.	Dielectric withstanding Voltage	500 V AC (50Hz or 60 Hz) shall be applied between all the adjacent terminals and between the terminal and the frame for 1 minute.	There shall be no breakdown or flashover.
	5.	Capacitance	1MHz±10kHz	5-pF max.
MECHANICAL PERFORMANCE	6.	Operation Force	Applied in the direction of operation. ON→OFF OFF→ON 	800gf Max



# NP□□-□□V SPECIFICATION

FILE No.	: E-V-AD16 (automation)
REV.	: A
Page	: 2 / 5

<b>MECHANICAL PERFORMANCE</b>	7	Stop Strength	A static load of 1 kgf is applied in the operating direction and pulling direction operated for a period of 60 seconds.	There shall be no sign of damage mechanically		
	8	Soldering Heat Resistance	1.Soldering Temperature :		As shown in item 1、2、3、4、6	
				TEMP		TIME
			NPI	260°C±5°C		5±1 sec.
			NPM	SEE PAGE 4/5		
			2.Frequency of Soldering Process: 2 times max. (PCB is 1.6mm in thickness.)			
9	Vibration	Shall be vibrated in accordance with Method 201A of MIL-STD-202F 1)Frequency: 10-55-10 Hz 1 min/cycle. 2)Direction: 3 vertical directions including the direction of operation. 3)Test Time: 2 hours each direction. 4) Swing distance=1.5mm	As shown in item 1、2、3、4、6			
10	Shock	Shall be shocked in accordance with Method 213B condition A of MIL-STD-202F 1)Acceleration: 50G. 2)Action Time : 11 ± 1 m sec. 3)Testing Direction: 6 sides. 4)Test cycle:3 times in each direction	As shown in item 1、2、3、4、6			
11	Solderability	1)NP-V Soldering Temperature:245±3°C Lead-Free solder : M705E JIS Z 3282 Class A (Tin 96.5% , Silver 3% , Copper 0.5%) 2)Flux: 5-10 seconds. 3)Duration of solder Immersion: 5±1 sec.	No anti-soldering and the coverage of dipping into solder must more than 75% was requested.			
<b>DURABILITY</b>	12	Operation Life	Measurements shall be made following the test set forth below: 1)10 mA, 5V DC resistive load 2)Rate of Operation: 15~20 cycles/minute 3)Cycle of Operation: 2000 cycles.	1)As shown in item 1、3、4 2)Contact Resistance: 200mΩ max.		



# NP□□-□□V SPECIFICATION

FILE No. : E-V-AD16 (automation)  
REV. : A  
Page : 3 / 5

WEATHER-PROOF	13	Resistance Low Temperature	Following the test set forth below the sample shall be left in normal temperature and humidity conditions for an hour before measurements are made : 1.Temperature : $-40\pm 3^{\circ}\text{C}$ 2.Time: 96 hours	As shown in item 2、3、4、6
	14	Resistance High Temperature	Following the test set forth below the sample shall be left in normal temperature and humidity conditions for an hour before measurements are made : 1.Temperature : $85^{\circ}\text{C}\pm 2^{\circ}\text{C}$ 2.Time: 96 hours	1.As shown in item 3、4、6 2.Contact Resistance: 200mΩ max.
	15	Resistance Humidity	Following the test set forth below the sample shall be left in normal temperature and humidity conditions for an hour before measurements are made : 1.Temperature : $85^{\circ}\text{C}\pm 2^{\circ}\text{C}$ 2.Relative Humidity :90~95% 3.Time: 96 hours	1.As shown in item 1、4、6 2.Contact Resistance: 200mΩ max. 3.Insulation Resistance : 100MΩ min.



# NP□□-□□V SPECIFICATION

FILE No.

: E-V-AD16 (automation)

REV.

: A

Page

: 4 / 5

## 5. NP□□-□□□□-□□V TYPE :

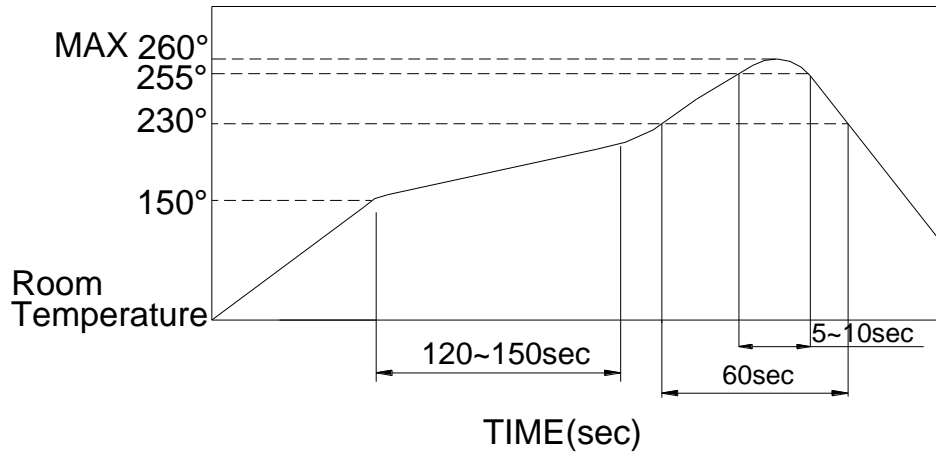

- The condition mentioned above is the temperature on the Cu foil of the PCB surface. There are cases where board's temperature greatly differs from switch's surface temperature depending on board's material, size, thickness, etc. Care, therefore, should be used not to allow switch's surface temperature to exceed 260°C.

### ■ Manual Soldering

Soldering Temperature	Max,350°C
Continuous Soldering Time	Max, 5 seconds

### ■ Precautions in Handling

1. Avoid flux penetrates into switch on PCB

1. Don't clean the switch body except with top tape sealed type, which can only spray of cleaning method from top of s/w.
2. Please make sure the switch at OFF position in reflow process, or it may reduce operation force and increase contact resistance if it's at on position.
3. If FLUX is foamed type, the height of foaming surface must be controlled, and it should not exceed the surface of the PCB where the S.W is placed. If the FLUX foaming surface exceeds the surface of the PCB, it may penetrate into the inside of the S.W and cause poor conduction.
4. Don't wash the switch itself

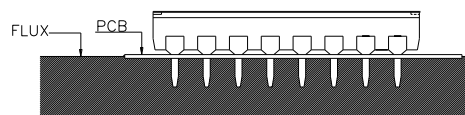



# NP□□-□□V SPECIFICATION

FILE No.	: E-V-AD16 (automation)
REV.	: A
Page	: 5 / 5

■ Notes on storage conditions:

Do not store in the following environment or it may affect product's function and solderability:

1. environment with corrosive gas
2. place of direct sunlight

Store with proper packaging conditions and to avoid loading heavy force

We suggest to use the products within 3 months or at least 6 months.

After opening the package, the rest products must be stored in the appropriate moisture-proof & airtight environment

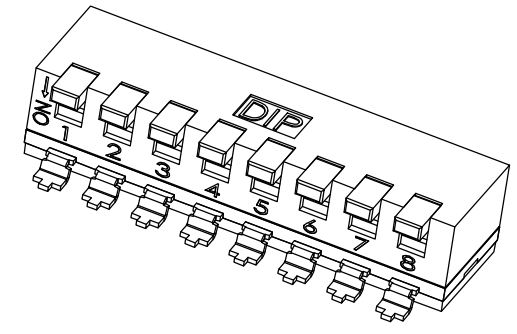
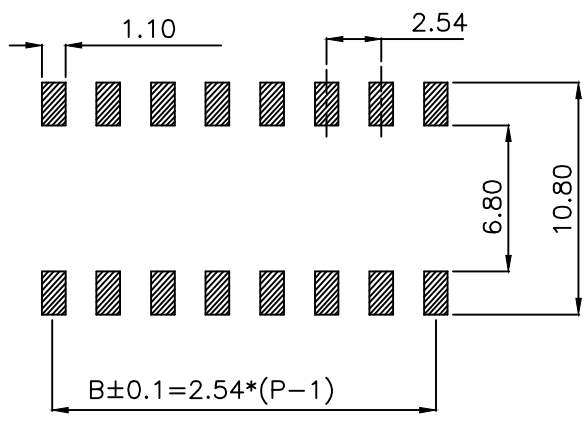
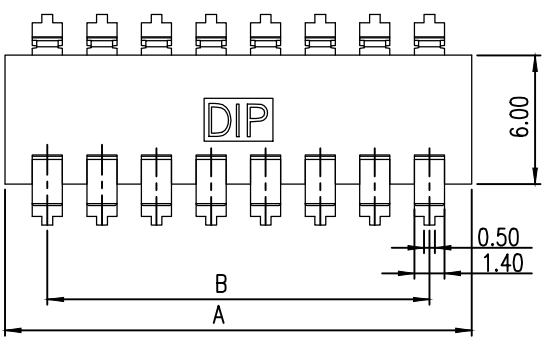

P.C.B. LAYOUT

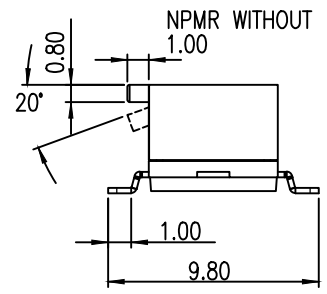
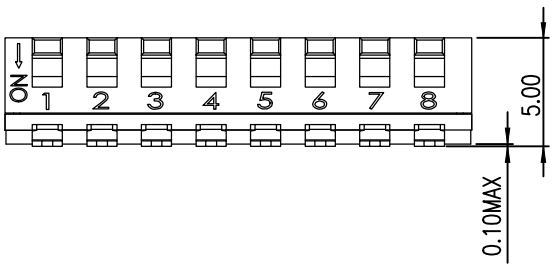

NPM(R)-10V	10	26.80	22.86
NPM(R)-08V	8	21.72	17.78
NPM(R)-06V	6	16.64	12.70
NPM(R)-04V	4	11.56	7.62
NPM(R)-02V	2	6.48	2.54
PROD. NO.	NO. OF POS.	DIM. A	DIM. B

NOTE:  
 1. ALL DIMENSIONS ARE IN MILLIMETERS,  
 2. GENERAL TOLERANCES ±0.20mm.  
 3. MATERIAL & \* :SEE SPECIFICATION.  
 4. P:Pitch=2.54mm

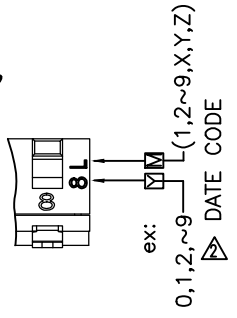

SCHEMATIC(TYP.)

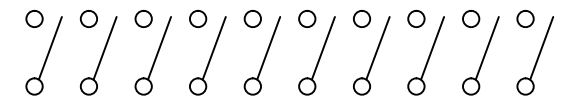

CIRCUIT DIAGRAM

4			
3			
B1	依<工變22160>執行變更	2022.10.19	林后謙
A	技通21095新增	2021.07.21	林后謙
ZONE REV.	DESCRIPTION	DATE	APPD.

APPD: 林后謙	QTY:
CHKD: 陳曉柏	SCALE: 4:1
DR: Paggi	REV: B1
DESIGN:	UNITS: mm

**國達實業股份有限公司**  
 DIPTRONICS MANUFACTURING INC.

PART NAME:	PIANO S.M.T. TYPE DIP SWITCH
DWG NO:	NPM(automation)

ITEM	DESC	Q'TY	METERIALS	TREATMENT	REMARK
1	ACTUATOR	*	HIGH - TEMP. THERMOPLASTIC PA46 UL 94V-0	MOLDED WHITE	-
2	CONTACT	*	COPPER	Gold Plated 0.075um min .	-
3	BASE	1	HIGH - TEMP. THERMOPLASTIC NYLON 9T UL 94V-0	MOLDED BLACK	-
4	COVER	1	HIGH - TEMP. THERMOPLASTIC NYLON 9T UL 94V-0	MOLDED BLACK	-
5	TERMINAL	1	BRASS	Gold Plated 0.075um min .	-
6	TAPE		KAPTON	-	-

N P   -     V R

R=Tape & Reel (S.M.T Type Only)

=Tube

Soldering: V=Lead Free Solder able

Seal:

=Regular

T =Top Tape Sealed

<Recessed Actuator Only>

=Push Down On

F =Push Down OFF

Number Of Positions:

02.04.06.08.10 Positions.

Actuator Type:

=Raised Actuator

R=Recessed Actuator

Terminal Type:

M= S.M.T Type

I= Through Hole Type

New Piano type

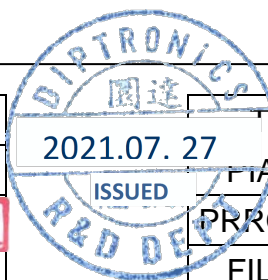
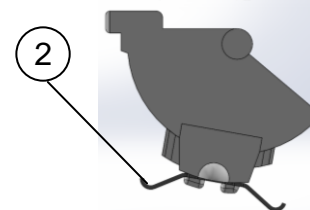
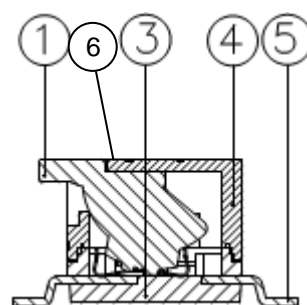

			TITLE :	APPD. :	林嚴政
			PIANO TYPE DIP SWITCH	CHKD. :	潘淑暖
A	技通 21095	林嚴政	PRROD. NO. :	PR. :	paggy
REV.	ECO. NO.	APPD.	FILE NO. :	REV. :	A SHEET : 1/1