

REVISION			
LTR	DESCRIPTION	DATE	APP
AO	NEW RELEASE	05/18/2021	PECK

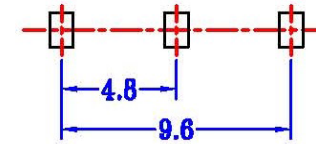

**P.C.B LAYOUT
BOTTOM VIEW**

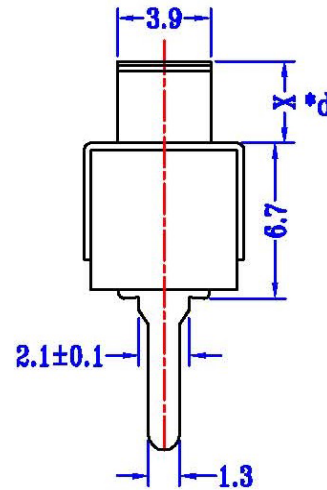
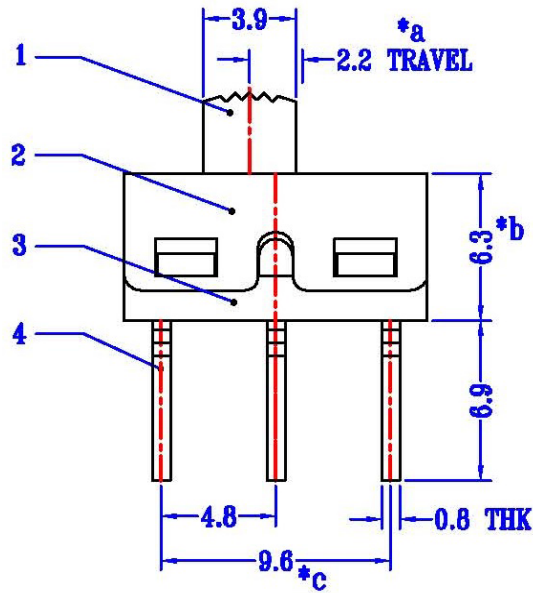
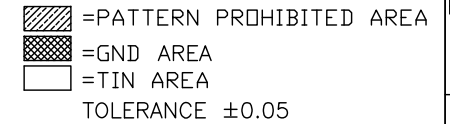
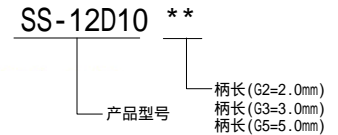

Note:

1.Material:

- 1.1 Housing: High temperature thermoplastic,UL94v-0
- 1.2 Orbit: High temperature thermoplastic,UL94v-0
- 1.3 Contact: copper alloy;
Gold plated contact area;Tin plated solder area
- 1.4 Shell:Stainless;Ni plated allover;
Gold plated solder area

2.Specification:

- 2.1 Current rating: **3.0A** Max
- 2.2 Voltage rating: **24V** DC
- 2.3 Dielectric withstanding voltage:
500V(AC) for 1 min.
- 2.4 Contact resistance: 100mΩ Max.
- 2.5 Insulation resistance: 1000MΩ min.
- 2.6 Temperature range: -25°C~85°C
- 2.7 Mating cycle:15000 cycles min
- 2.8 Insert force: 40N Max
Extration force: 0.5~40N

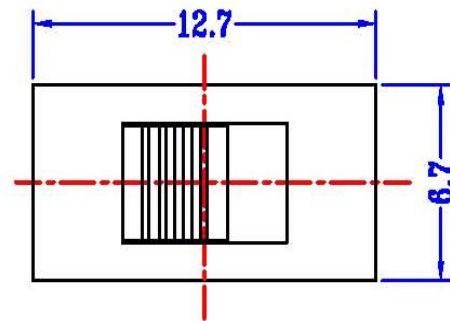

DIMENSION CLASSIFICATION		台灣碩方精密電子科技有限公司 TAIWAN SOFNG PRECISION ELECTRONIC CO., LTD		SOFNG	
■ : CRITICAL		TITLE		SS-12D10G5 立插式 中大型拨动开关	
☒ : MAJOR		TOLERANCE TABLE		開關, 連接器	
		PART NO.		SD106	
.X	± 0.40	APPROVED	Peck	DWG NO.	SS-12D10
.XX	± 0.25	CHECKED	Paul	SCALE 1:1	UNIT mm SIZE A4
.XXX	± 0.10	DRAWIN	David	REV AO	SHEET NO. 1/1
ANGLE	± 2°				