

# TMD2620

## Proximity Sensor Module

### General Description

The device is an advanced proximity sensor. The slim module incorporates an IR LED and factory calibrated LED driver. The proximity detection feature provides object detection (e.g. mobile device screen to user's ear) by photodiode detection of reflected IR energy (sourced by the integrated LED).

Detect/release events are interrupt driven, and occur when proximity result crosses upper and/or lower threshold settings.

The proximity engine features offset adjustment registers to compensate for unwanted IR energy reflection at the sensor. Proximity results are further improved by automatic ambient light subtraction.

*Ordering Information and Content Guide appear at end of datasheet.*

**Figure 1:**  
Added Value of Using TMD2620

Benefits	Features
<ul style="list-style-type: none"> <li>Reduced board space requirements and enables low-profile system design</li> </ul>	<ul style="list-style-type: none"> <li>Small footprint and low profile package</li> <li>3.10 x 2.00 x 1.00 mm</li> </ul>
<ul style="list-style-type: none"> <li>Reduced power consumption</li> </ul>	<ul style="list-style-type: none"> <li>0.18µm process technology with 1.8V I<sup>2</sup>C bus</li> </ul>

### Applications

The TMD2620 is ideal for mobile phone touch screen disable.

### Block Diagram

The functional blocks of this device are shown below:

**Figure 2:**  
Functional Blocks of TMD2620

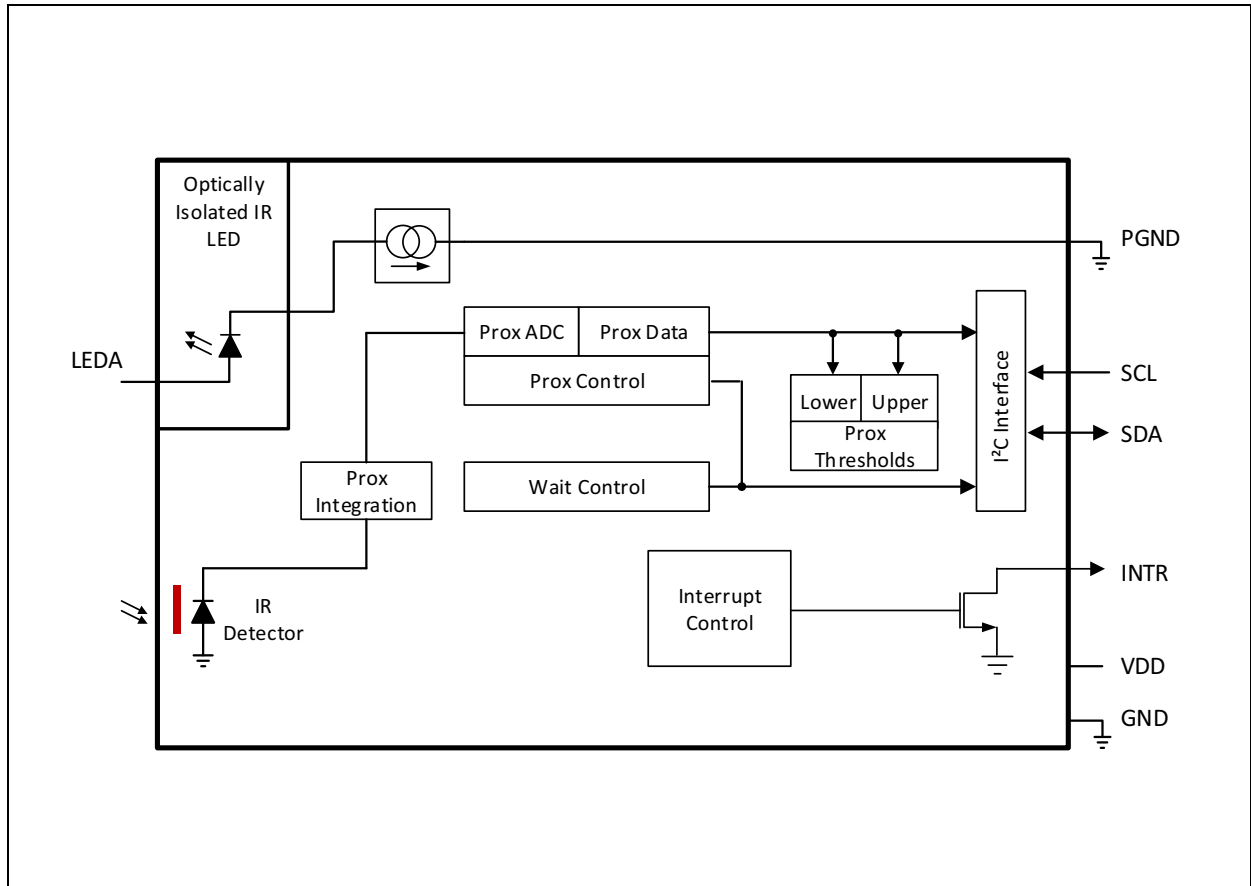

## Pin Assignment

**Figure 3:**  
TMD2620 Pinout (Top View)

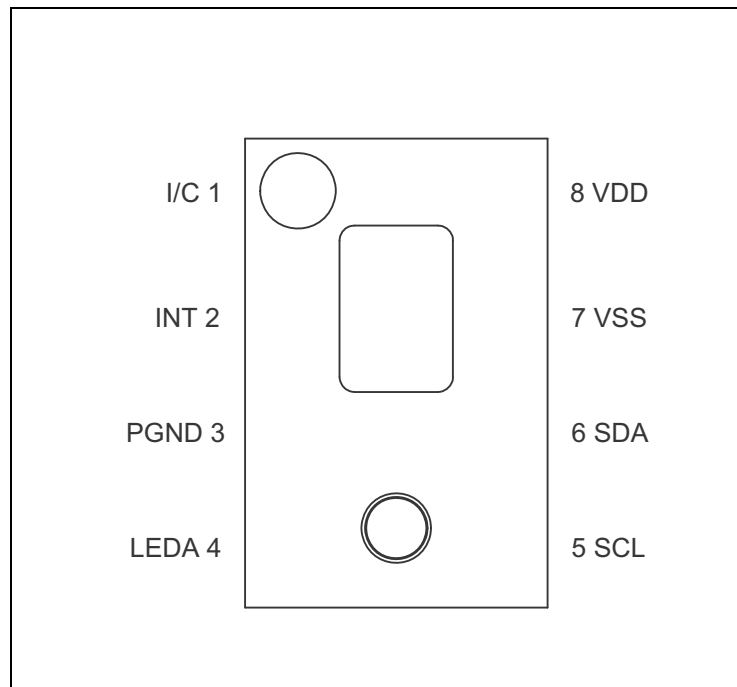

**Figure 4:**  
Pin Description

Pin Number	Pin Name	Description
1	I/C	Internal connection. Connect to ground.
2	INT	Interrupt. Open drain output (active low)
3	PGND	Ground for LED current sink and I/O buffers
4	LEDA	LED anode
5	SCL	I <sup>2</sup> C serial clock input
6	SDA	I <sup>2</sup> C serial data I/O terminal
7	VSS	Ground. All voltages are referenced to GND
8	VDD	Supply voltage

## Absolute Maximum Ratings

Stresses beyond those listed under [Absolute Maximum Ratings](#) may cause permanent damage to the device. These are stress ratings only. Functional operation of the device at these or any other conditions beyond those indicated under [Recommended Operating Conditions](#) is not implied. Exposure to absolute maximum rating conditions for extended periods may affect device reliability.

**Figure 5:**  
Absolute Maximum Ratings

Symbol	Parameter	Min	Max	Units
VDD	Supply voltage	-0.3	2.2	V
LEDA	Supply voltage	-0.3	3.6	V
V <sub>IO</sub>	Digital I/O terminal voltage	-0.3	3.6	V
(SDA, INT)	Output terminal current	-1	20	mA
T <sub>STRG</sub>	Storage temperature range	-40	85	°C
I <sub>SCR</sub>	Input current (latch up immunity) JEDEC JESD78D Nov 2011	CLASS 1		
ESD <sub>HBM</sub>	Electrostatic discharge HBM S-001-2014	±2000		V
ESD <sub>CDM</sub>	Electrostatic discharge CDM JEDEC JESD22-C101F Oct 2013	±500		V

## Electrical Characteristics

**Figure 6:**  
Recommended Operating Conditions

Symbol	Parameter	Min	Typ	Max	Units
$V_{DD}$	Supply voltage	1.7	1.8	2.0	V
$V_{LEDA}$	Voltage supplied to LEDA pin		3.3		V
$T_A$	Operating free-air temperature <sup>(1)</sup>	-30		85	°C

**Note(s):**

1. While the device is operational across the temperature range, performance will vary with temperature. Operational characteristics are at 25°C, unless otherwise noted.

**Figure 7:**  
Operating Characteristics,  $V_{DD} = 1.8\text{ V}$ ,  $T_A = 25^\circ\text{C}$  (unless otherwise noted)

Symbol	Parameter	Conditions	Min	Typ	Max	Units
$f_{OSC}$	Oscillator frequency			8.0		MHz
IDD	Supply current <sup>(1)</sup>	Idle state (PON=1, PEN=0) <sup>(2)</sup>		30		μA
		Sleep state <sup>(3)</sup>		0.7	5.0	μA
VOL	INT, SDA output low voltage	6 mA sink current			0.6	V
ILEAK	Leakage current, SDA, SCL, INT pins		-5		5	μA
VIH	SCL, SDA input high voltage		1.26			V
VIL	SCL, SDA input low voltage				0.54	V

**Note(s):**

1. Values are shown at the VDD pin and do not include current through the IRLED.
2. Idle state occurs when PON=1 and all functions are not enabled.
3. Sleep state occurs when PON = 0 and I<sup>2</sup>C bus is idle. If Sleep state has been entered as the result of operational flow, SAI = 1, PON will remain high.

**Figure 8:**  
**Proximity Optical Characteristics of TMD2620**

Parameter	Conditions	Min	Typ	Max	Unit
Part to part variation <sup>(1)</sup>	Conditions: PGAIN = 2 (4x) PLDRIVE = 8 (54mA) PPULSE = 15 (16 pulses) PPULSE_LEN = 1 (16µs) d=23mm round target 30mm target distance	75	100	125	%
Response, absolute	Basic proximity measurement <sup>(2)</sup> Conditions: PGAIN = 2 (4x), PLDRIVE = 7(48mA) PPULSE = 15 (16 pulses) PPULSE_LEN = 2 (16µs) Target material: 90% reflective surface of Kodak gray card Target Size: 100mm x 100mm Target Distance: 60mm	82	103	123	Counts
Response, no target using offset values from 0xE6 and 0xE7	PGAIN = 2 (4x) ILEDDRIVE = 16 (102mA) PPULSE = 16 (17 Pulses) Pulse Length = 2 (16µS)	0		10	
Noise/Signal <sup>(3)</sup>	PGAIN = 2 (4x) IRLEDDRIVE = 8 (54mA) PPULSE = 15 (16 pulses) PPULSE_LEN = 1 (8µs) d=23mm round target 30mm target distance			1	%

**Note(s):**

1. Production tested result is the average of 5 readings expressed relative to a calibrated response.
2. Representative result by characterization.
3. Production tested result is the average of 20 readings divided by the average response.

**Figure 9:**  
Proximity Operation

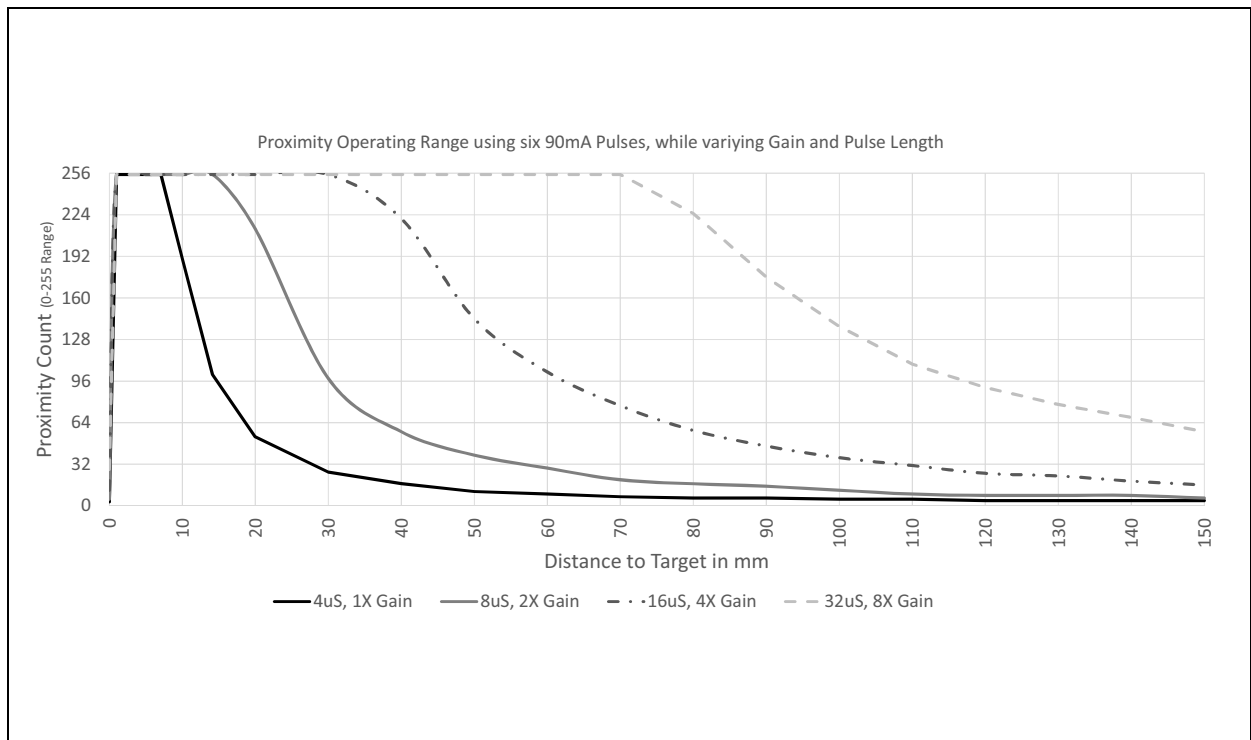

**Figure 10:**  
Proximity Angular Spectral Response

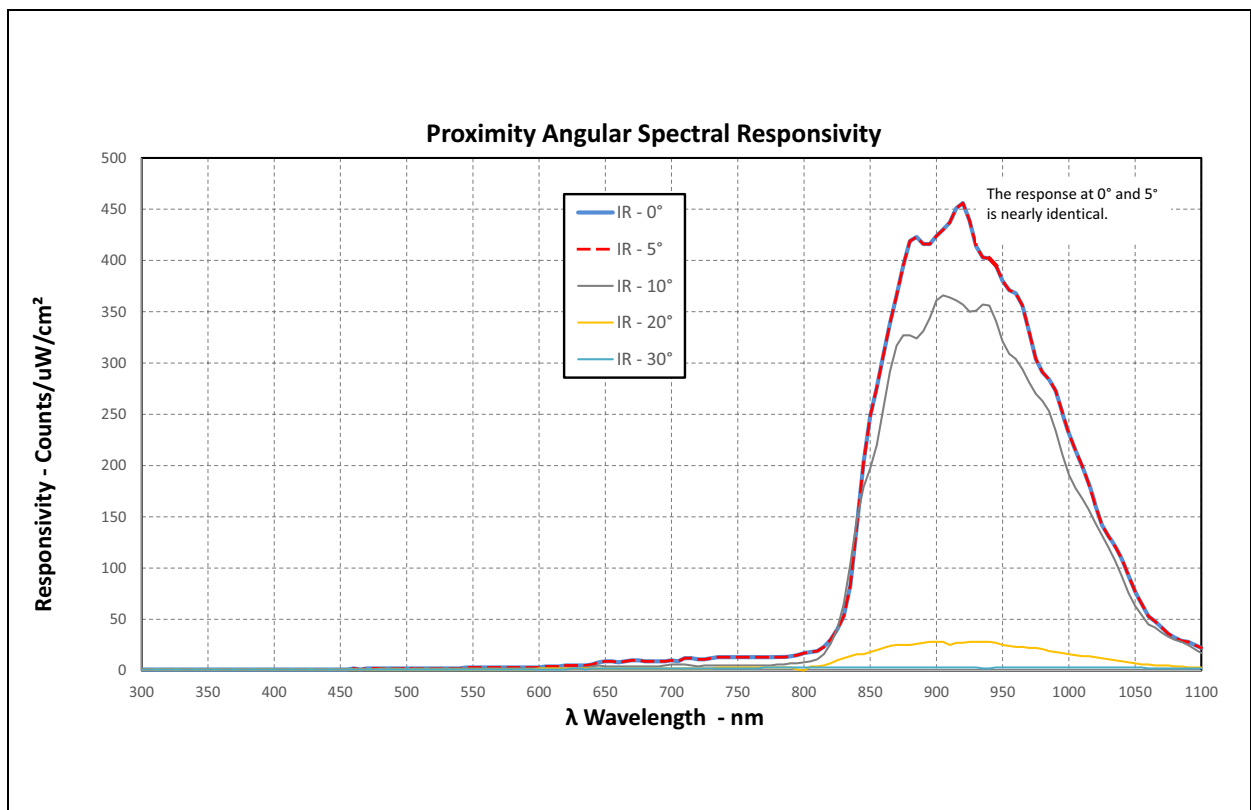

## Register Description

Device address is 0x29.

**Figure 11:**  
Register Overview

Address	Register Name	R/W	Register Function	Reset Value
0x80	ENABLE	R/W	Enables states and interrupts	0x00
0x82	PRATE	R/W	Proximity sample rate	0x1F
0x83	WTIME	R/W	Wait time	0x00
0x88	PILT	R/W	Proximity interrupt low threshold	0x00
0x8A	PIHT	R/W	Proximity interrupt high threshold	0x00
0x8C	PERS	R/W	Proximity interrupt persistence filters	0x00
0x8D	CFG0	R/W	WTIME configuration	0x80
0x8E	PCFG0	R/W	Proximity pulse width and count	0x4F
0x8F	PCFG1	R/W	Proximity gain and LED current	0x80
0x91	REVID	R	Revision ID	
0x92	ID	R	Device ID	0xD4
0x93	STATUS	R, SC	Device status register one	0x00
0x9C	PDATA	R	Proximity ADC data register MSBs	0x00
0x9E	REVID2	R	Reserved	0x00
0x9F	CFG2	R/W	Configuration register two	0x00
0xAB	CFG3	R/W	Configuration register three	0x0C
0xC0	POFFSET_L	R/W	Proximity offset value	0x00-0xFF
0xC1	POFFSET_H	R/W	Proximity offset sign	0x00-0xFF
0xD7	CALIB	R/W	Calibration control	0x00
0xD9	CALIBCFG	R/W	Calibration configuration	0x00
0xDC	CALIBSTAT	R/W	Calibration status bit	0x00
0xDD	INTENAB	R/W	Interrupt enables	0x00

### Register Access:

- R = Read Only
- W = Write Only
- R/W = Read or Write
- SC = Self Clearing after access

## ENABLE Register (0x80)

Figure 12:  
ENABLE Register

0x80: ENABLE				
Field	Name	Reset	Type	Description
7:4	Reserved	0	RW	Reserved
3	wen	0	RW	Wait Enable. This bit activates the wait feature. Writing a one activates the wait timer. Writing a zero disables the wait timer.
2	pen	0	RW	Proximity Detect Enable. This field activates the proximity detection.
1	Reserved	0	RW	Reserved
0	pon	0	RW	Power On. This field activates the internal oscillator to permit the timers and ADC channels to operate. Writing a one activates the oscillator. Writing a zero disables the oscillator.

The Mode/Parameter fields should be written before pen is asserted. The function pen require pon to be asserted for the respective function to operate correctly.

## PRATE Register (0x82)

Figure 13:  
PRATE Register

0x82: PRATE				
Field	Name	Reset	Type	Description
7:0	prate	0x1F	RW	When averaging is turned on, this register defines the time between proximity measurements. The time will be 88 $\mu$ s times this register's value.

### WTIME Register (0x83)

Figure 14:  
WTIME Register

0x83: WTIME						
Field	Name	Reset	Type	Description		
7:0	wtime	0x00	RW	Wait Time. Eight bit value that specifies the time		
				<b>Value</b>	<b>Wait Cycles</b>	<b>Wait Time</b>
				0x00	1	2.81ms/ 33.8ms
				0x01	2	5.6ms/ 67.6ms
				...	...	...
				0x3f	63	180ms/ 2.16s
				...	...	...
				0xff	255	721ms/ 8.65s

The wait timer is implemented with a down counter with 0x00 as the terminal count. Loading 0x00 will generate a 2.81ms wait time, loading 0x01 will generate a 5.6ms wait time, and so forth; by asserting wlong, in register 0x8D the wait time is given in multiples of 33.8ms (12x).

### PILT Register (0x88)

**Figure 15:**  
PILT Register

0x88: PILT				
Field	Name	Reset	Type	Description
7:0	pilt	0	RW	Proximity ADC Channel Low Threshold

This register provides the low interrupt threshold. If the value generated by the proximity channel is below the low threshold specified and the PPERS value is reached, the pint bit is asserted which will assert the INT pin if pien is set.

### PIHT Register (0x8A)

**Figure 16:**  
PIHT Register

0x8A: PIHT				
Field	Name	Reset	Type	Description
7:0	piht	0	RW	Proximity ADC Channel High Threshold

This register provides the high interrupt threshold. If the value generated by the proximity channel is above the high threshold specified and the PPERS value is reached, the pint bit is asserted which will assert the INT pin if pien is set.

**PERS Register (0x8C)**

This register controls the interrupt filtering capabilities of the device. Configurable filtering is provided to allow interrupts to be generated after a proximity cycle or if the integration cycle has produced a result that is outside of the values specified by threshold register for some specified number of times.

**Figure 17:**  
PERS Register

0x8C: PERS					
Field	Name	Reset	Type	Description	
7:4	ppers	0	RW	Proximity Persistence Filtering	
				<b>Value</b>	<b>Interrupt generated when...</b>
				0	Every proximity cycle
				1	Any proximity value outside of threshold range
				2	2 consecutive proximity values out of range
				3	3 consecutive proximity values out of range
				...	...
				15	15 consecutive proximity values out of range
3:0	Reserved	0	RW	Reserved	

**CFG0 Register (0x8D)**

**Figure 18:**  
CFG0 Register

0x8D: CFG0				
Field	Name	Reset	Type	Description
7:3	Reserved	1 0 0 0 0	RW	Reserved. Must be set to 10000.
2	wlong	0	RW	Wait Long. When asserted, the wait cycle is increased by a factor 12x from that programmed in the WTIME register.
1:0	Reserved	0 0	RW	Reserved. Must be set to 00.

## PCFG0 Register (0x8E)

Figure 19:  
PCFG0 Register

0x8E: PCFG0					
Field	Name	Reset	Type	Description	
7:6	ppulse_len	1	RW	Proximity Pulse Length	
				<b>Value</b>	<b>Pulse Length</b>
				0	4 $\mu$ s
				1	8 $\mu$ s
				2	16 $\mu$ s
				3	32 $\mu$ s
5:0	ppulse	15	RW	Maximum Number of Pulses in Proximity	
				<b>Value</b>	<b>Number of Pulses</b>
				0	1
				1	2
				2	3
				...	...
				63	64

**PCFG1 Register (0x8F)**

**Figure 20:**  
PCFG1 Register

0x8F: PCFG1					
Field	Name	Reset	Type	Description	
7:6	pgain	2	RW	Proximity Gain Control. Sets the gain of the proximity receiver.	
				<b>Value</b>	<b>Gain Value</b>
				0	1x
				1	2x
				2	4x
				3	8x
5	Reserved	0	RW	Reserved	
4:0	pldrive	0	RW	Proximity LED Drive Strength. This is configured linearly in steps of 6mA, this is the nominal value. The actual value depends on the trim procedure.	
				<b>Value</b>	<b>LED Current</b>
				0	6mA
				1	12mA
				...	...
				31	192mA

**REVID Register (0x91)**

**Figure 21:**  
REVID Register

0x91: REVID				
Field	Name	Reset	Type	Description
7:3	Reserved	0	RO	Reserved
2:0	rev_id		RO	Revision Number Identification

## ID Register (0x92)

**Figure 22:**  
ID Register

0x92: ID					
Field	Name	Reset	Type	Description	
7:2	ID	0x35	RO	Part Number Identification	
				<b>Value</b>	<b>Meaning</b>
				110101	TMD2620
1:0	Reserved	00	RO	Reserved	

### STATUS Register (0x93)

Figure 23:  
STATUS Register

0x93: STATUS				
Field	Name	Reset	Type	Description
7	Reserved	0	R, SC	Reserved
6	psat	0	R, SC	Proximity Saturation. Indicates that an ambient- or reflective-saturation event occurred during a previous proximity cycle. Writing a 1 will clear this status flag; to enable clear-by-read function, the register CFG3.int_read_clear must be set 1
5	pint	0	R, SC	Proximity Interrupt. Indicates that the device is asserting a proximity interrupt. Writing a 1 will clear this status flag; to enable clear-by-read function, the register CFG3.int_read_clear must be set 1
4	Reserved	0	R, SC	Reserved
3	cint	0	R, SC	Calibration Interrupt. Writing a 1 will clear this status flag; to enable clear-by-read function, the register CFG3.int_read_clear must be set 1
2	zint	0	R, SC	Zero Detection Interrupt. Writing a 1 will clear this status flag. Enable clear-byread with CFG3
1	psat_reflective	0	R, SC	psat interrupt is from reflective light saturation writing a 1 to psat or psat_reflective will clear this status flag; to enable clear-by-read function, the register CFG3.int_read_clear must be set 1
0	psat_ambient	0	R, SC	psat interrupt is from ambient light or idac threshold saturation writing a 1 to psat or psat_ambient will clear this status flag; to enable clear-by-read function, the register CFG3.int_read_clear must be set 1

STATUS flags are reset with reading from STATUS address, or with writing 1 to dedicated bits of STATUS address.

### PDATA Register (0x9C)

Figure 24:  
PDATA Register

0x9C: PDATA				
Field	Name	Reset	Type	Description
7:0	pdata	0	RO	This register contains the 8-bit proximity data.

### REVID2 Register (0x9E)

Figure 25:  
REVID2 Register

0x9E: REVID2				
Field	Name	Reset	Type	Description
7:4	Reserved	0	RO	Reserved
3:0	aux_id	0	RO	TBD

### CFG3 Register (0xAB)

Figure 26:  
CFG3 Register

0xAB: CFG3																								
Field	Name	Reset	Type	Description																				
7	int_read_clear	0	RW	If set to 1, interrupt flags in STATUS register (0x93) are reset after I <sup>2</sup> C reads to the STATUS register; otherwise the interrupt flags will not be reset.																				
6:5	Reserved	0	R, SC	Reserved. Set to 0.																				
4	sai	0	RW	Sleep After Interrupt: Power down the device at the end of the proximity cycle if an interrupt has been generated. <sup>(1)</sup>																				
				<table border="1"> <thead> <tr> <th>PON</th> <th>SAI</th> <th>INT (low active)</th> <th>Oscillator</th> </tr> </thead> <tbody> <tr> <td>0</td> <td>x</td> <td>x</td> <td>OFF</td> </tr> <tr> <td>1</td> <td>0</td> <td>x</td> <td>ON</td> </tr> <tr> <td>1</td> <td>1</td> <td>1</td> <td>ON</td> </tr> <tr> <td>1</td> <td>1</td> <td>0</td> <td>OFF (SAI induced sleep)</td> </tr> </tbody> </table>	PON	SAI	INT (low active)	Oscillator	0	x	x	OFF	1	0	x	ON	1	1	1	ON	1	1	0	OFF (SAI induced sleep)
				PON	SAI	INT (low active)	Oscillator																	
				0	x	x	OFF																	
				1	0	x	ON																	
				1	1	1	ON																	
1	1	0	OFF (SAI induced sleep)																					
The way to “wake up” the device from SAI-sleep is by clearing the interrupt register 0x93.																								
3:0	Reserved	1100	RW	Reserved. Set to 0.																				

**Note(s):**

1. SAI does not modify any register bits directly, it rather uses the interrupt signal to turn OFF the oscillator.

### POFFSET\_L Register (0xC0)

Figure 27:  
POFFSET\_L Register

0xC0: POFFSET_L				
Field	Name	Reset	Type	Description
7:0	poffset_l	0x00-0xFF	R, SC	Offset compensation for proximity channel (magnitude)

### POFFSET\_H Register (0xC1)

Figure 28:  
POFFSET\_H Register

0xC1: POFFSET_H				
Field	Name	Reset	Type	Description
0	poffset_h	0x00-0xFF	R, SC	Offset compensation for proximity channel (sign)

### CALIB Register (0xD7)

Figure 29:  
CALIB Register

0xD7: CALIB				
Field	Name	Reset	Type	Description
7:6	Reserved	0	RO	Reserved. Set to 0.
5	electrical_calibration	0	RW_SM	If set, do electrical offset calibration (diodes disabled) instead of optical. Otherwise, do optical calibration. In either case, the result is stored in the POFFSET_L/H registers. This flag is cleared after calibration is completed. This flag is redundant, software could just: set gdiode_disab=0xf set concap_intinn=1 start calibration. However, since electrical calibration is done automatically at the first time PON gets asserted, the function is there anyway, so it's made available to the user here.
4:1	Reserved	0	WS_SC	Reserved. Set to 0.
0	start_offset_calib	0	RW_SM	Start Offset Calibration. The result is stored in the POFFSET registers. The calib_finished flag is asserted afterwards. Calibration can be stopped by writing a 0 to this bit.

### CALIBCFG Register (0xD9)

Figure 30:  
CALIBCFG Register

0xD9: CALIBCFG					
Field	Name	Reset	Type	Description	
7:5	binsrch_target	0x2	RW	ADC target during binary search	
				<b>Value</b>	<b>Target</b>
				0	0
				1	1
				2	3
				3	7
				4	15
				5	31
				6	63
				7	127
				<b>Note:</b> This target is relative to 8-bit ADC values. In the circuit, a 10-bit target is used (x4) of which the lowest 2 bits are always ignored when checking for zero during binary search and zero detection. In hardware, this defines a mask of which bits to ignore when comparing to zero. e.g. binsrch_target=4 (target=15) means that values from the ADC are AND'ed with 0xffc0 before comparing to zero. Only values 16 or larger are taken as positive ADC values.	
4	Reserved	0	RW	Reserved. Set to 0.	
3	prox_auto_offset_adjust	0	SC	This bit enables an automatic adjustment of the offset used in proximity measurements. If this bit is set, when a measurement returns zero, the value of 0xC0 will be decremented and offset_adjusted flag will be set, bit 2 in 0xDC.	

0xD9: CALIBCFG					
Field	Name	Reset	Type	Description	
2:0	prx_data_avg	0	R_PUSH	Prox data calculation is done by averaging consecutive windows of constant size. At the end of the window, PDATA is updated. Typical use case is HRM measurement	
				<b>Value</b>	<b>Window Size</b>
				0	disable
				1	2
				2	4
				3	8
				4	16
				5	32
				6	64
				7	128

**CALIBSTAT Register (0xDC)**

Figure 31:  
CALIBSTAT Register

0xDC: CALIBSTAT				
Field	Name	Reset	Type	Description
7:3	Reserved	0		Reserved
2	offset_adjusted	0	SC	This bit is a flag that the automatic proximity offset adjustment has changed the offset in register 0xDC. See 0xD9 for "prox_auto_offset_adjust".
1	Reserved	0		Reserved
0	calib_finished	0	R/W	Offset calibration has finished. Clear bit by writing '1' to it. Bit generates interrupt if cien is asserted.

**INTENAB Register (0xDD)****Figure 32:**  
**INTENAB Register**

0xDD: INTENAB				
Field	Name	Reset	Type	Description
6	psien	0	RW	Writing '1' to this bit enables psat.
5	pien	0	RW	Writing '1' to this bit enables prox interrupt.
3	cien	0	RW	Writing '1' to this bit enables calibration interrupt.
2	zien	0	RW	Writing '1' to this bit enables zero_detection/offset_adjustment.

## Application Information

**Figure 33:**  
Typical Application Hardware Circuit

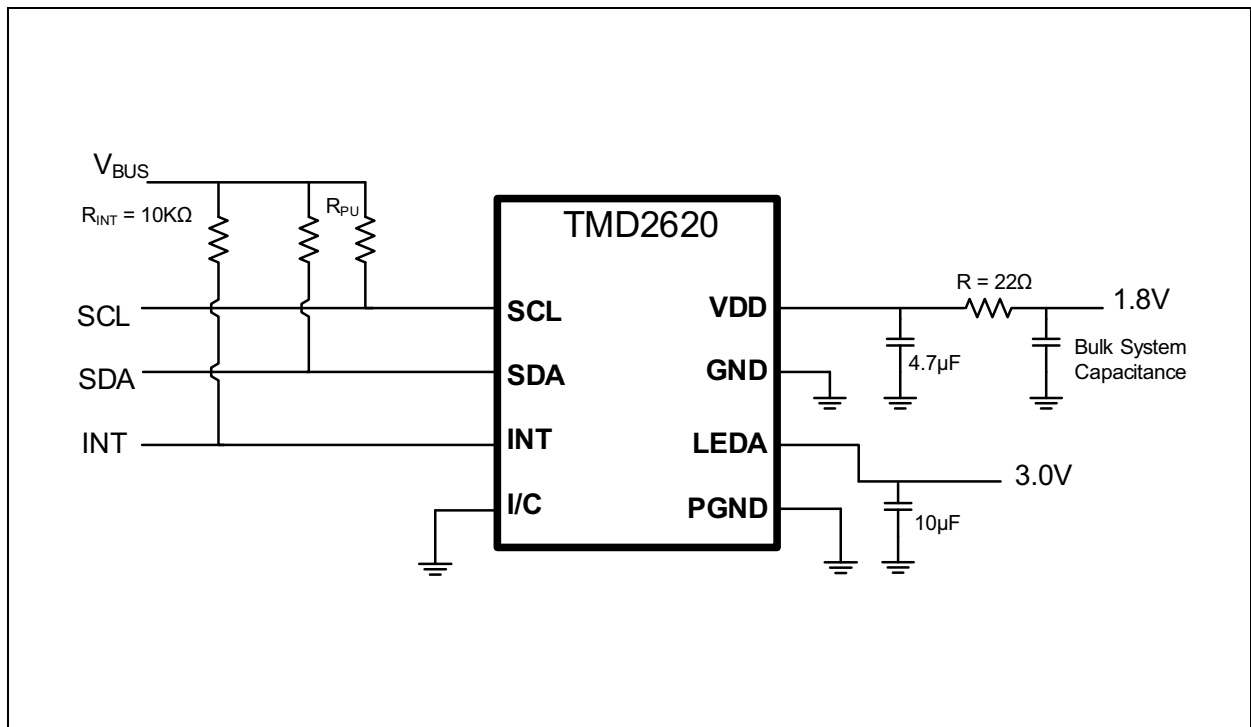

**Note(s):**

1. Place the 4.7μF and 10μF capacitors within 5mm of the module.
2. The value of the I<sup>2</sup>C pull up resistors R<sub>PU</sub> should be based on the 1.8V bus voltage, system bus speed and trace capacitance.
3. The bulk capacitor can affect the stability of a regulated supply output and should be chosen with the regulator characteristics in mind.
4. GND and PGND should be connected to the same solid ground plane as close to the device as possible.

## PCB Pad Layout

**Figure 34:**  
Recommended PCB Pad Layout

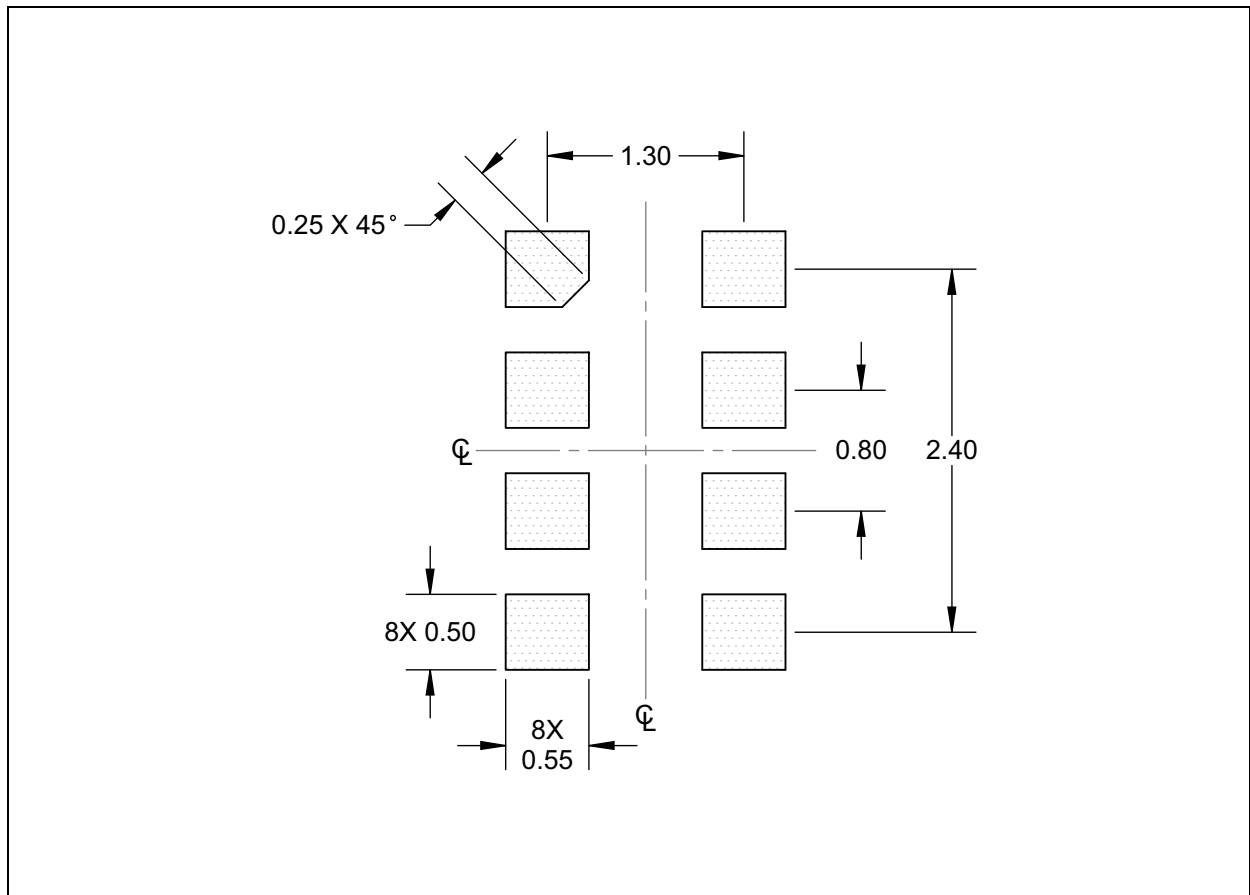

**Note(s):**

1. All linear dimensions are in millimeters.
2. Dimension tolerances are 0.05mm unless otherwise noted.
3. This drawing is subject to change without notice.

### Packaging Mechanical Data

Figure 35:  
Package Drawing

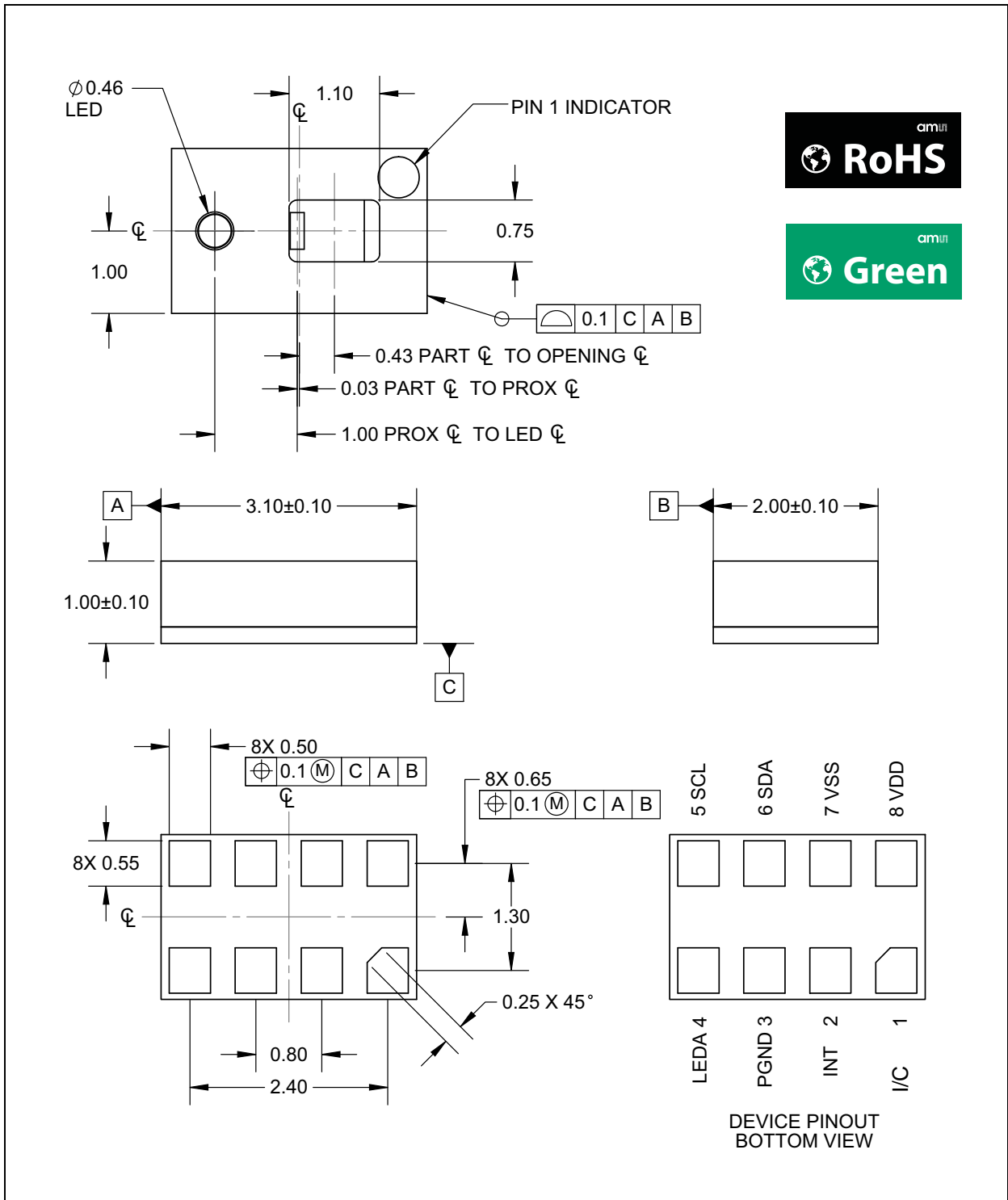

**Note(s):**

1. All linear dimensions are in millimeters.
2. Dimension tolerances are 0.05mm unless otherwise noted.
3. Contact finish is Au.
4. This package contains no lead (Pb).
5. This drawing is subject to change without notice.

## Tape & Reel Information

**Figure 36:**  
Tape & Reel Information

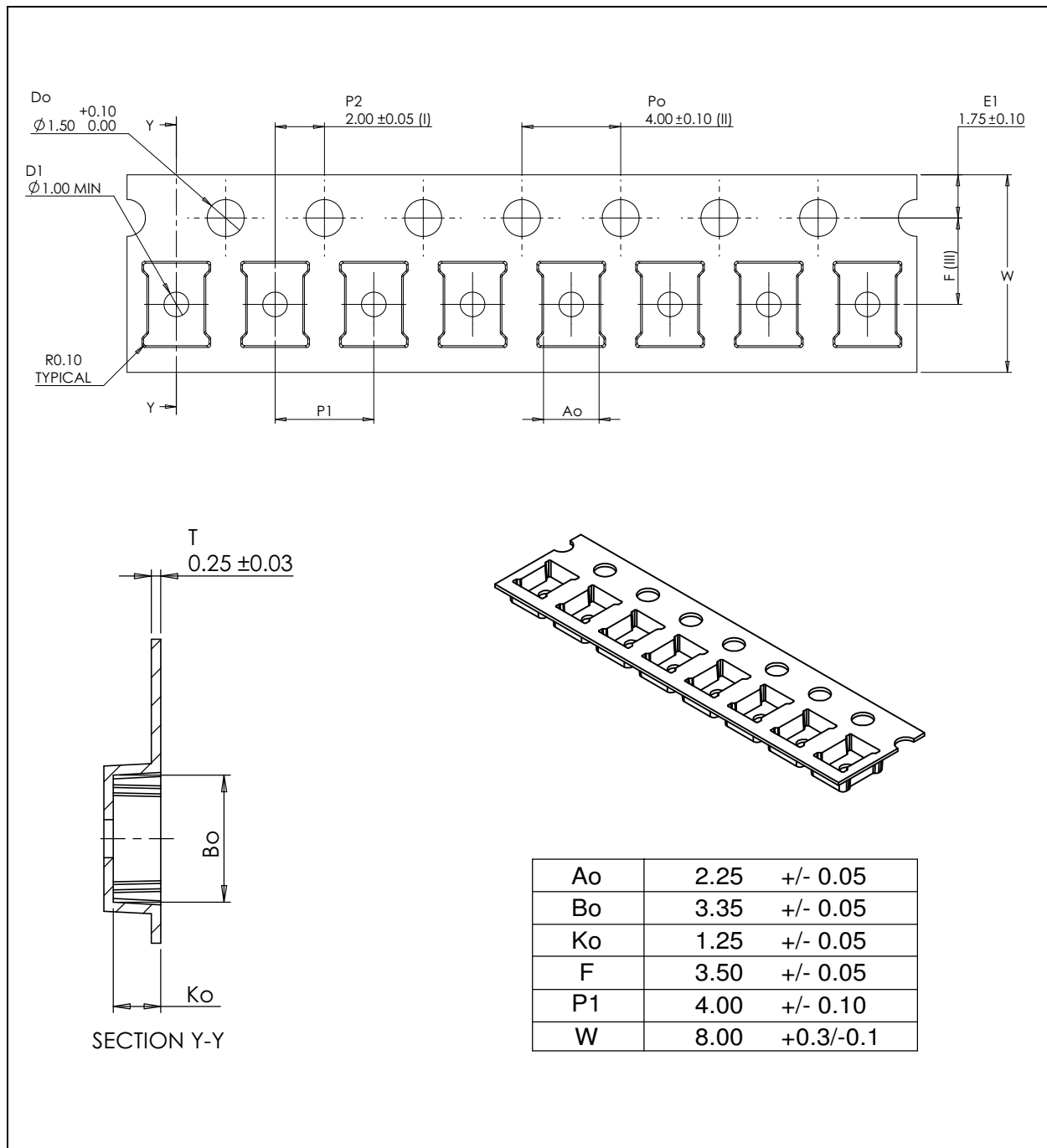

**Note(s):**

1. Measured from centreline of sprocket hole to centreline of pocket.
2. Cumulative tolerance of 10 sprocket holes is  $\pm 0.20$ .
3. Measured from centreline of sprocket hole to centreline of pocket.
4. Other material available.

### Soldering & Storage Information

The module has been tested and has demonstrated an ability to be reflow soldered to a PCB substrate.

The solder reflow profile describes the expected maximum heat exposure of components during the solder reflow process of product on a PCB. Temperature is measured on top of component. The components should be limited to a maximum of three passes through this solder reflow profile.

**Figure 37:**  
Solder Reflow Profile

Parameter	Reference	Device
Average temperature gradient in preheating		2.5°C/s
Soak time	$t_{soak}$	2 to 3 minutes
Time above 217°C ( $T_1$ )	$t_1$	Max 60 s
Time above 230°C ( $T_2$ )	$t_2$	Max 50 s
Time above $T_{peak} - 10\text{ °C}$ ( $T_3$ )	$t_3$	Max 10 s
Peak temperature in reflow	$T_{peak}$	260°C
Temperature gradient in cooling		Max -5°C/s

**Figure 38:**  
Solder Reflow Profile Graph

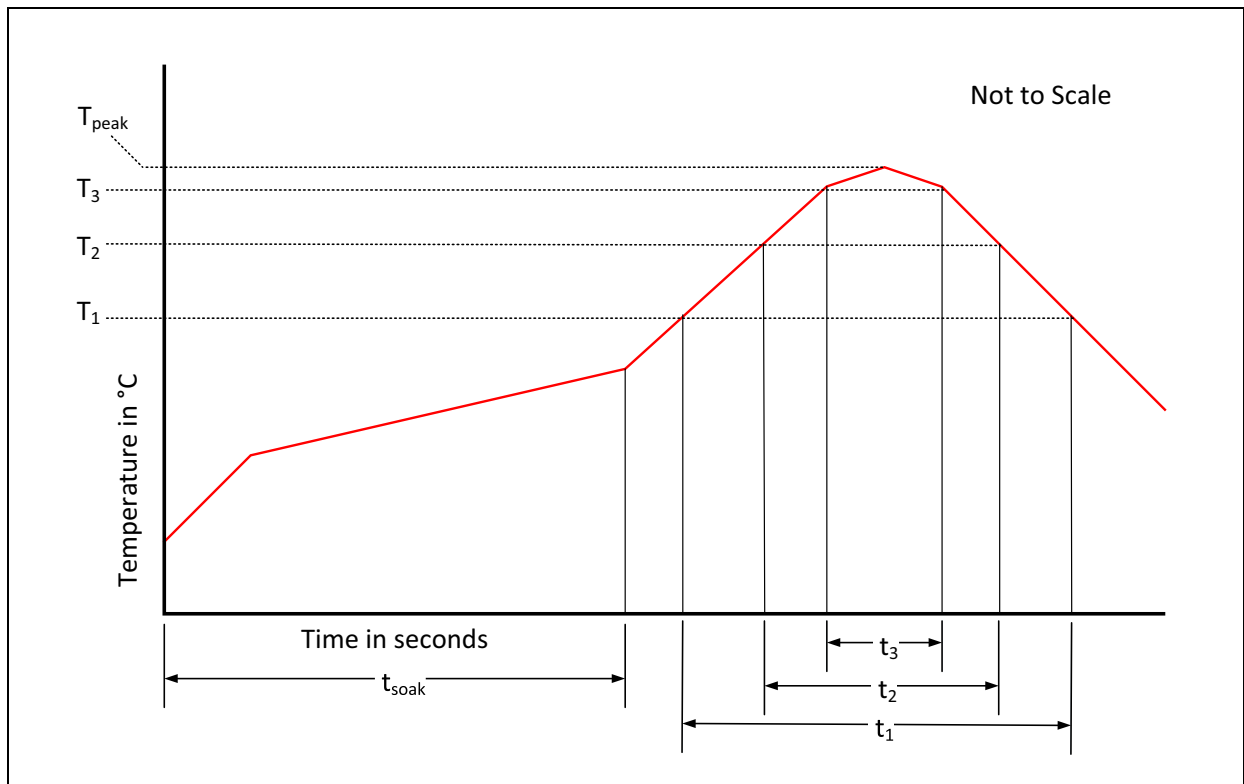

## Storage Information

### **Moisture Sensitivity**

Optical characteristics of the device can be adversely affected during the soldering process by the release and vaporization of moisture that has been previously absorbed into the package. To ensure the package contains the smallest amount of absorbed moisture possible, each device is baked prior to being dry packed for shipping.

Devices are dry packed in a sealed aluminized envelope called a moisture-barrier bag with silica gel to protect them from ambient moisture during shipping, handling, and storage before use.

### **Shelf Life**

The calculated shelf life of the device in an unopened moisture barrier bag is 12 months from the date code on the bag when stored under the following conditions:

- Shelf Life: 12 months
- Ambient Temperature: <40°C
- Relative Humidity: <90%

Rebaking of the devices will be required if the devices exceed the 12 month shelf life or the Humidity Indicator Card shows that the devices were exposed to conditions beyond the allowable moisture region.

### **Floor Life**

The module has been assigned a moisture sensitivity level of MSL 3. As a result, the floor life of devices removed from the moisture barrier bag is 168 hours from the time the bag was opened, provided that the devices are stored under the following conditions:

- Floor Life: 168 hours
- Ambient Temperature: <30°C
- Relative Humidity: <60%

If the floor life or the temperature/humidity conditions have been exceeded, the devices must be rebaked prior to solder reflow or dry packing.

### **Rebaking Instructions**

When the shelf life or floor life limits have been exceeded, rebake at 50°C for 12 hours.

## Ordering & Contact Information

Figure 39:  
Ordering Information

Ordering Code	Package	I <sup>2</sup> C Addr	Delivery Form	Delivery Quantity
TMD26203	Module	29h	3.30mm reel	5000 pcs/reel
TMD26203M	Module	29h	3.30mm reel	1000 pcs/reel

Buy our products or get free samples online at:

[www.ams.com/ICdirect](http://www.ams.com/ICdirect)

Technical Support is available at:

[www.ams.com/Technical-Support](http://www.ams.com/Technical-Support)

Provide feedback about this document at:

[www.ams.com/Document-Feedback](http://www.ams.com/Document-Feedback)

For further information and requests, e-mail us at:

[ams\\_sales@ams.com](mailto:ams_sales@ams.com)

For sales offices, distributors and representatives, please visit:

[www.ams.com/contact](http://www.ams.com/contact)

### Headquarters

ams AG

Tobelbader Strasse 30

8141 Premstaetten

Austria, Europe

Tel: +43 (0) 3136 500 0

Website: [www.ams.com](http://www.ams.com)

## RoHS Compliant & ams Green Statement

**RoHS:** The term RoHS compliant means that ams AG products fully comply with current RoHS directives. Our semiconductor products do not contain any chemicals for all 6 substance categories, including the requirement that lead not exceed 0.1% by weight in homogeneous materials. Where designed to be soldered at high temperatures, RoHS compliant products are suitable for use in specified lead-free processes.

**ams Green (RoHS compliant and no Sb/Br):** ams Green defines that in addition to RoHS compliance, our products are free of Bromine (Br) and Antimony (Sb) based flame retardants (Br or Sb do not exceed 0.1% by weight in homogeneous material).

**Important Information:** The information provided in this statement represents ams AG knowledge and belief as of the date that it is provided. ams AG bases its knowledge and belief on information provided by third parties, and makes no representation or warranty as to the accuracy of such information. Efforts are underway to better integrate information from third parties. ams AG has taken and continues to take reasonable steps to provide representative and accurate information but may not have conducted destructive testing or chemical analysis on incoming materials and chemicals. ams AG and ams AG suppliers consider certain information to be proprietary, and thus CAS numbers and other limited information may not be available for release.

## Copyrights & Disclaimer

Copyright ams AG, Tobelbader Strasse 30, 8141 Premstaetten, Austria-Europe. Trademarks Registered. All rights reserved. The material herein may not be reproduced, adapted, merged, translated, stored, or used without the prior written consent of the copyright owner.

Devices sold by ams AG are covered by the warranty and patent indemnification provisions appearing in its General Terms of Trade. ams AG makes no warranty, express, statutory, implied, or by description regarding the information set forth herein. ams AG reserves the right to change specifications and prices at any time and without notice. Therefore, prior to designing this product into a system, it is necessary to check with ams AG for current information. This product is intended for use in commercial applications. Applications requiring extended temperature range, unusual environmental requirements, or high reliability applications, such as military, medical life-support or life-sustaining equipment are specifically not recommended without additional processing by ams AG for each application. This product is provided by ams AG "AS IS" and any express or implied warranties, including, but not limited to the implied warranties of merchantability and fitness for a particular purpose are disclaimed.

ams AG shall not be liable to recipient or any third party for any damages, including but not limited to personal injury, property damage, loss of profits, loss of use, interruption of business or indirect, special, incidental or consequential damages, of any kind, in connection with or arising out of the furnishing, performance or use of the technical data herein. No obligation or liability to recipient or any third party shall arise or flow out of ams AG rendering of technical or other services.

## Document Status

Document Status	Product Status	Definition
Product Preview	Pre-Development	Information in this datasheet is based on product ideas in the planning phase of development. All specifications are design goals without any warranty and are subject to change without notice
Preliminary Datasheet	Pre-Production	Information in this datasheet is based on products in the design, validation or qualification phase of development. The performance and parameters shown in this document are preliminary without any warranty and are subject to change without notice
Datasheet	Production	Information in this datasheet is based on products in ramp-up to full production or full production which conform to specifications in accordance with the terms of ams AG standard warranty as given in the General Terms of Trade
Datasheet (discontinued)	Discontinued	Information in this datasheet is based on products which conform to specifications in accordance with the terms of ams AG standard warranty as given in the General Terms of Trade, but these products have been superseded and should not be used for new designs

## Revision Information

Changes from 1-00 (2016-Jun-28) to current revision 1-01 (2016-Aug-02)	Page
Added note under Figure 35	24
Updated Figure 39	28

**Note(s):**

1. Page and figure numbers for the previous version may differ from page and figure numbers in the current revision.
2. Correction of typographical errors is not explicitly mentioned.

## Content Guide

- 1 General Description**
  - 1 Applications
  - 2 Block Diagram
  
- 3 Pin Assignment**
- 4 Absolute Maximum Ratings**
- 5 Electrical Characteristics**
  
- 8 Register Description**
  - 9 ENABLE Register (0x80)
  - 10 PRATE Register (0x82)
  - 10 WTIME Register (0x83)
  - 11 PILT Register (0x88)
  - 11 PIHT Register (0x8A)
  - 12 PERS Register (0x8C)
  - 13 CFG0 Register (0x8D)
  - 14 PCFG0 Register (0x8E)
  - 15 PCFG1 Register (0x8F)
  - 15 REVID Register (0x91)
  - 16 ID Register (0x92)
  - 17 STATUS Register (0x93)
  - 17 PDATA Register (0x9C)
  - 18 REVID2 Register (0x9E)
  - 18 CFG3 Register (0xAB)
  - 19 POFFSET\_L Register (0xC0)
  - 19 POFFSET\_H Register (0xC1)
  - 19 CALIB Register (0xD7)
  - 20 CALIBCFG Register (0xD9)
  - 21 CALIBSTAT Register (0xDC)
  - 22 INTENAB Register (0xDD)
  
- 23 Application Information**
- 24 PCB Pad Layout**
- 25 Packaging Mechanical Data**
- 26 Tape & Reel Information**
  
- 27 Soldering & Storage Information**
  - 28 Storage Information
  - 28 Moisture Sensitivity
  - 28 Shelf Life
  - 28 Floor Life
  - 28 Rebaking Instructions
  
- 29 Ordering & Contact Information**
- 30 RoHS Compliant & ams Green Statement**
- 31 Copyrights & Disclaimer**
- 32 Document Status**
- 33 Revision Information**